

Manual Bin Lift System

OMNITRADE (e)



30991

Table of Content

| | |
|--|-----------|
| Foreword | 4 |
| 1 Introduction | 6 |
| 1.1 Description of the bin lift system | 6 |
| 1.2 Technical specifications | 7 |
| 2 Safety | 9 |
| 2.1 General safety | 9 |
| 2.2 Safety instructions during operation, maintenance and repair | 10 |
| 2.2.1 During operation of the bin lift system | 10 |
| 2.2.2 During maintenance and repair | 11 |
| 2.3 Emergency stop button | 11 |
| 2.4 Safety signs | 14 |
| 3 Bin lift operation | 16 |
| 3.1 Operator panel | 16 |
| 3.2 Warning and tips | 16 |
| 3.3 Daily checks | 17 |
| 3.4 Loading bags and / or bulky waste | 18 |
| 3.5 Loading with the pick-up comb - 2 wheel bins | 19 |
| 3.6 Loading with the pick-up comb - 4 wheel containers | 21 |
| 3.6.1 Single Man Trade (SMT) | 23 |
| 3.7 Loading with the pick-up arms(optional) | 25 |
| 3.8 Travel height and foot boards | 26 |
| 4 Maintenance and cleaning | 28 |
| 4.1 General maintenance | 28 |
| 4.2 Daily maintenance | 28 |
| 4.3 Weekly maintenance | 29 |
| 4.4 Six-weekly maintenance | 31 |
| 4.5 Annual maintenance | 32 |
| 4.6 Six monthly maintenance Omnitrade e | 33 |
| 4.7 Two yearly maintenance Omnitrade e | 33 |
| 4.8 Four yearly maintenance Omnitrade e | 33 |
| 4.9 Troubleshooting | 33 |
| 4.10 Fault blink code | 34 |
| 4.11 Open the hydraulic system | 34 |
| 4.12 Alarm codes | 36 |
| 5 Dimensions bin lift system and compactor body | 46 |
| 5.1 Dimensions of the bin lift system | 46 |
| 5.2 Required dimensions of the compactor body | 47 |
| 6 Installation | 48 |
| 6.1 Installation on the body | 48 |
| 6.2 Installation of the body (without mounting frame) | 50 |
| 6.3 Footboards: installation advice | 51 |
| 6.4 Hydraulic connection | 52 |
| 6.5 Electrical connection | 54 |
| 6.6 Installation push button control station | 57 |
| 7 Hydraulics | 59 |
| 7.1 Hydraulic connections and components | 59 |
| 8 Electrical | 63 |
| 8.1 Electrical connections and components (P&P) (UK version) | 63 |
| 8.2 Electrical diagram | 65 |
| 9 Decommissioning (disposal) | 66 |
| 9 Terberg Connect | 67 |
| 10 Options | 68 |

Foreword

This user manual provides information about the operation and maintenance of the OMNITRADE (e) Manual Bin Lift System.

In order to work safely and efficiently with this Manual Bin Lift System, it is essential that you read this manual carefully before putting the bin lift into use.

The operation and appearance of components and button control stations may differ, this depends on the version ordered.

Make the user manual available to everyone involved with the operation and /or the maintenance of the bin lift.

Where necessary, refer to the user manual of the refuse collection vehicle and the refuse handling body.

You can use the bin lift safely when all the operating and maintenance instructions have been met. Should you nonetheless have any further questions, please get in touch with your distributor.

Translation

This is a translation of the original instruction, issue date 12/21.

Intended Use

Use the bin lift system as described in this manual, to handle 2-wheel bins, 4-wheel containers and bag collection or bulky waste.

Any other use of the bin lift system is forbidden.

Warranty

For more information about the conditions of warranty, please contact your distributor.

Operator requirements

- The bin lift system may only be operated by persons who are familiar with the operation of the bin lift.
- Repairs may only be carried out by qualified personnel.

Symbols used

NOTE:



NOTE

Additional information.

CAUTION:



CAUTION

If these instructions are not followed, this may result in slight to average injury and/or damage to the product or the environment.

WARNING:



WARNING

If these instructions are not followed, this may result in serious or fatal injury and/or serious damage to the product or the environment.

Content

The user manual mainly has the following chapters:

1. *Introduction*

A description of the function, conditions of use and the operating principle of the machine.

2. *Safety*

Description of the safety provisions and the measures that need to be taken into account in order to work safely with the machine. As well as an explanation of the symbols on the machine.

3. *Operating*

A clear description of the most important components, instructions for emptying various types of containers and information about the Diagnostic System if present.

4. *Maintenance and cleaning*

Covers all the periodic operations needed for the correct functioning of the machine, trouble shooting and fault diagnosis.

5. *Transport and storage*

Information about the weight, the center of gravity and how to store the machine.

6. *Installation and commissioning*

A description of the installation dimensions of the machine when being built onto the RCV (Refuse Collection Vehicle), including a list of means and tooling required to conduct the installation.

7. *Decommissioning*

Description of the actions necessary to dismantle the machine safely and to dispose of the machine in an environmentally-friendly manner.

Type indication

Each bin lift is provided with a type plate with the type indication, machine number and year of construction. The type plate can be found on the R /H side of the frame.

| | | |
|---|--|---|
|  | Terberg Machines B.V. Baronieweg 23 3403 NL IJsselstein Nederland Tel. +31 (0)30 210 06 00 www.terbergmachines.nl | Bin lift system Beladingsysteem Léve-conteneurs Schüttungssystem |
| |  | |
| TYPE | TCH-BL-2.2 | |
| FABR. NR. MANUF. NR. HERSTELL. NR. | 000000000000 | |
| | BOUWJAAR YEAR OF MANUF. ANNEE DE CONSTR. BAUJAHR | 2021 |

1 Introduction

1.1 Description of the bin lift system

The OMNITRADE (e) is a versatile bin lift system. This bin lift system is suitable for emptying 2-wheel bins as well as 4-wheel containers. With the (optional) pick-up arms, 4-wheel containers that are not fitted with a comb pick-up edge can be emptied.

The OmniTRADE can be supplied with an integral mounting frame (available in widths of 2.2 and 2.5 metres). There is a button control station (03) on the L/H side tilt arm, with which the container can be partly lifted, with the rest of the cycle being completed using the standard control station on the L/H or R/H side.

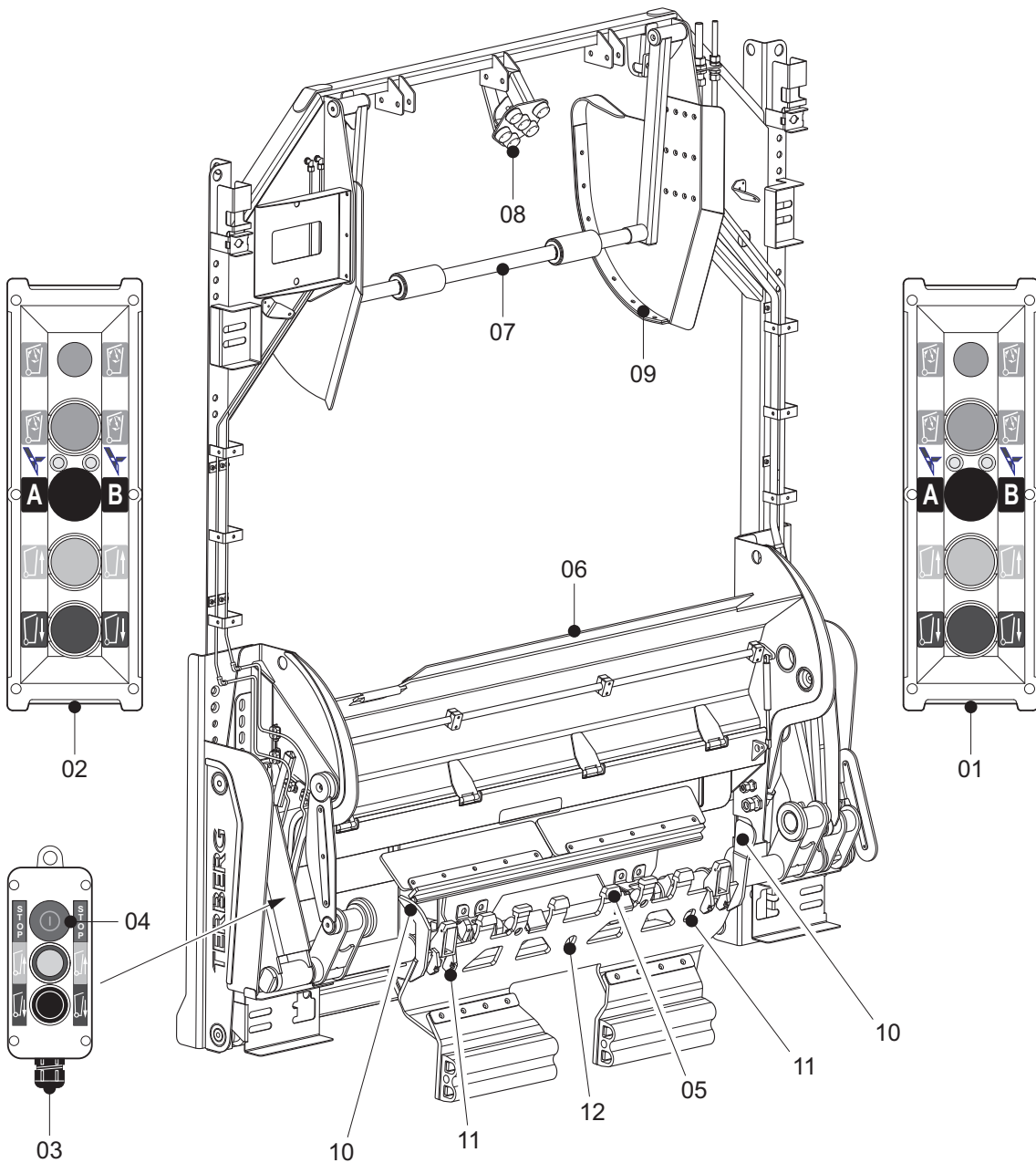

Bin lift details

| | |
|---|---|
| 01/02 - Button control station R/L ; * | 08 - Container stop, 4-wheel containers |
| 03 - Button control station for container pick-up | 09 - Lid opener |
| 04 - Emergency stop | 10 - Bin guide plate |
| 05 - Pick-up comb | 11 - Start sensors |
| 06 - Refuse guide plate (guide flap) | 12 - Sensor for 4-wheel container |
| 07 - Catcherbar , 2 wheel bins and 4-wheel containers | |

1.2 Technical specifications

The bin lift is an 'interchangeable lifting device' in compliance with EN 1501-5:2012.



This bin lift system has been designed for mounting onto refuse collection vehicles that are fitted with a standard interface (mechanical, hydraulic, electrical).



Technical data OMNITrade

| | |
|---|---|
| Guidelines and standards | 2006/42/EG, EN 1501-1 & EN 1501-5: 2012 |
| Weight | 685 kg |
| Noise level (according EN1501-4 6.4.3) | 65 dB (A) |
| Vibrations | ≤ 2.5 m/s ² |
| Operating voltage | 24 Volts DC |
| Maximum current consumed by controls | 10 Ampère / 24V DC |
| Required oil flow | 30-60 litres/ minute |
| Required working pressure | Minimum 190 bar / Maximum 250 bar |
| Return pressure | Maximum 2.0 bar |

Technical data OMNITrade (e)

| | |
|--|---|
| Guidelines and standards | 2006/42/EG, EN 1501-1 & EN 1501-5: 2012 |
| Weight | 730 kg |
| Noise level (according EN1501-4 6.4.3) | 65 dB (A) |
| Vibrations | ≤ 2.5 m/s ² |
| Operating voltage | 24 Volts DC |
| Maximum current consumed by controls | 10 Ampère / 24V DC |
| Average power consumption during normal day use | 20 Amps free alternator capacity |
| Average electrical power 2-wheel bin | 1.7 kW |
| Maximum electrical power 2-wheel bins (1000N) | 2.2 kW |
| Maximum electrical power 4-wheel containers (5000N) | 4.5 kW |

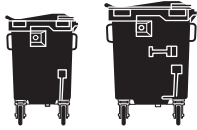
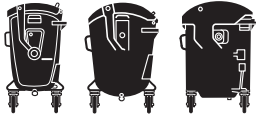
Bin/container and bin lift information

| | 2-wheel bins | 4-wheel containers with flat lif | 4-wheel containers with roll top | Chamberlain /Paladin containers |
|-----------------------|---|--|--|---|
| |  |  |  |  |
| Capacity (litres) | 80-390 | 500-770 1000-1280 | 770-1100 | 900 |
| According to standard | EN 840-1 | EN 840-2 | EN 840-3 | |
| Lifting capacity | 1600N (160 kg) | | 7500N (750 kg) | |
| Cycle time | ±11.5 seconds | | ±10 seconds | |
| Emptying time | adjustable | | | |
| Automatic emptying | no | no | no | no |
| Manual emptying | yes | yes | yes | yes |
| Pick-up via comb | yes | yes | yes | yes |
| Pick-up arms | not applicable | optional | optional | not applicable |
| Lid opener | not applicable | not applicable | yes | not applicable |
| Bin stop / catcherbar | position A working position | 500-770 Position A working position 1000-1280 position B folded away | position B folded away | position B folded away |



CAUTION

To empty bin/container types other than those listed above, is not permitted with this bin lift system. If in doubt, contact your distributor.

2 Safety

2.1 General safety

Terms of conformity

This bin lift conforms to the current standards at the time of production. The bin lift has been tested and checked, on a rig, in normal conditions with an increase of 25% weight in static and 10% weight in dynamic operation.

It is the end user's responsibility to maintain the equipment in accordance with the manufacturer's recommendations. If there is a risk of damages or injury the bin lift must be taken out of service immediately.

General

- Never operate the bin lift system when the refuse collection vehicle is travelling along and also not with reverse gear engaged.
- The bin lift may only be operated by persons who have received operator training. They must be fully familiar with the working of the bin lift.
- Read the operating instructions carefully before taking the bin lift into service.
- Also read the instructions for the compactor carefully.
- You will be working where traffic is present during your daily work as operator of the bin lift. Do not endanger yourself or other road users during your daily operations with the bin lift.
- Before commencing the run discuss and agree with your colleagues how to act in particular situations such as stopping, driving away, etc.
- When you are working with the bin lift system do not wear any loose hanging clothing or jewelry.
- Always wear work clothing, safety shoes and work gloves that comply with the standards shown in the table below while working with the bin lift.

| Personal protection equipment: | According to standard: |
|--------------------------------|------------------------|
| Work clothing | BS-EN-ISO 20471:2013 |
| Safety shoes | BS-EN-ISO 20345:2011 |
| Work gloves | BS-EN 420:2003+A1:2009 |

- Make sure that an unattended bin lift can never be started by a person who is not authorised to do so (remove ignition key whenever the vehicle is left unattended).
- Don't use the bin lift in areas or near installations where there is a risk of fire and /or explosion due to the presence of gases and/or combustible substances.
- Do not operate the bin lift if the oil flow is higher than 60 litres/minute.
- Technical faults must be reported immediately to the person who is responsible for the supervision of the bin lift. The bin lift must be put out of action until the fault (that could cause danger) has been repaired.
- Never use the lifting chair, pick-up arms or other parts of the bin lift system as a seat. This is life threatening!
- Never change the controls.
- Never remove or change any of the fitted safety provisions.
- Don't cover the ultrasonic sensors, fitted in the safety arms, under any circumstances.
- Damaged safety provisions must be repaired or replaced immediately by original parts.
- Never change the cycle speeds and lifting forces set by the manufacturer.
- Operating and safety decals must be present and properly legible.
- Actions that override the safety provisions are forbidden!
- Position the lifting chairs in their travel position before reversing.
- It is forbidden to stand on the foot boards while the refuse collection vehicle is reversing.
- Make sure that you are visible to the driver of the refuse collection vehicle when it is reversing.
- Never use the bin lift as a hoisting instrument.
- No vehicle may be towed with the towing cable attached to the bin lift system.

- Never lift the refuse collection vehicle by the lifting points of the bin lift.
- Fold the pick-up arms while the vehicle is in motion.
- Do not sit or stand on parts of the machine other than the foot boards when riding on the vehicle.
- In extremely bad weather (storms, thunderstorms, etc.) it is not advisable to use the bin lift system.

2.2 Safety instructions during operation, maintenance and repair

2.2.1 During operation of the bin lift system

- Make sure that there are no persons in the immediate vicinity of the bin lift during the loading cycle.
- When the bin lift system is operating, it is forbidden to put your hand in the bin lift system.
- In the event of danger immediately press the nearest emergency stop switch.
- Check that there are no foreign objects in or between bin lift system parts that could obstruct its working.
- Compacting may not be carried out when there are objects sticking out of the throw-in opening.
- Don't use the bin lift system in situations where there is poor visibility of the bin lift.
- Never use the bin lift system on a very uneven surface.
- The bin lift system may not be driven up against a container or a pile of refuse.
- Take account of the heating of the hydraulic oil. This can become 40°C warmer than the environment. As a result, the pipes and hoses can cause light burns at high ambient temperatures.
- It is not permitted to work with container types other than those stated in the manual.
- Nothing should protrude from the container and only containers whose lids are fully closed should be emptied.
- Don't empty damaged containers. This can cause problems.
- Overweight containers should be removed from the bin lift system.
- Check that the container is positioned correctly on the pick-up comb before emptying it.
- Let go of the container as soon as it is lifted.
- It is forbidden to assist the lifting cycle by hand.
- Only apply extra shaking if there is a need for this.
- Only take the container away when the bin lift has come to a standstill and the container is back on the ground.
- Overweight bins /containers should be removed from the bin lift system:
max. lifting capacity 2-wheel bins: 1600N (160 kg)
max. lifting capacity 4-wheel cont: 7500N (750 kg)
- Place empty containers where they will not cause a danger to other road users.
- It is forbidden to empty containers containing hazardous and /or radioactive substances.
- It is forbidden to empty containers containing smouldering or burning substances.
- Never walk backwards in the direction of the bin lift system.
- Keep to a minimum the simultaneous presenting and /or taking of two containers by one person.
- Only offer a container to the bin lift system when held by the handle bars.
- Always push a 2-wheel container to the bin lift with two outstretched arms.
- Never bend your body over the container when offering it to the bin lift.
- Under wintry conditions, if the bin lift is blocked with large amounts of ice or snow deposits, the sensors may become concealed or the container clamping mechanism may become clogged up.
- Press the emergency stop switch prior to cleaning. Clean these parts and keep them as dry as possible, for example with a broom. Never use defrosting liquids to clean the bin lift!



CAUTION

Keep a minimum distance of 2.5 meter between the bin lift and objects which are located behind the bin lift system. This is to avoid a dangerous situation in case that a bin / container falls from the pick-up comb.

2.2.2 During maintenance and repair

- Only qualified technical personnel is permitted to carry out maintenance or repairs.
- Correct any detected faults before using the bin lift system.
- Switch off the bin lift system during maintenance or repair work:
 - switch off the engine of the refuse collection vehicle;
 - switch off the main power switch.
- Remove the ignition key from the ignition switch during repair work. Keep it on your person. This prevents unintentional switching on of the machine.
- It is forbidden to work underneath the lifting chairs for repair or cleaning unless the lifting chairs are adequately supported.
- Switch off the drive of the refuse collection vehicle before you start cleaning.
- Wear safety glasses. It is possible that grease can squirt out from the hinge points when you use a high-pressure cleaner.
- Use the lifting points provided to raise the bin lift.
- When working on the hydraulic system:
 - Always use personal protection equipment to avoid contact with skin and eyes;
 - Use collecting trays / absorbents to avoid environmental pollution.
- Comply with the maintenance interval prescribed by the manufacturer.
- Never bridge or replace electrical fuses by a fuse with a higher capacity.
- When dismantling, disconnect the plugs and couplings from the vehicle.
- Following a collision involving the bin lift system Terberg must assess whether the bin lift system is still safe to use or first needs to be repaired.
- Always use original or specified parts for repair or maintenance.
- Do not stand under the bin lift.
- Do not stand under the bin / container.



CAUTION

Repairs may only be carried out by qualified personnel. Never rectify faults yourself. Rectifying faults by unqualified personnel may cause harm to people and damage to the bin lift system.

2.3 Emergency stop button

General



NOTE

When the bin lift system does not work or malfunctions while collecting refuse, immediately inform the workshop or service station. Give a clear description of the defect.

Emergency stop button

In case of emergency use the emergency stop button. A pushed button immediately stops the compactor and the loading cycle of the bin lift.

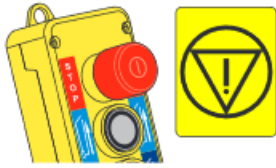

1. Press the red emergency button.

Now:

- The supply of hydraulic oil stops and the electrical circuit is interrupted.
- The check lights for automatic working extinguish.
- The driver of the refuse collection vehicle is warned by a buzzer that someone pressed the emergency stop button.

Reset emergency stop button

1. Pull out the emergency stop button to reset it.



The buzzer in the cabin stops,

2. Press the dark blue DOWN button to lower the lifting chair

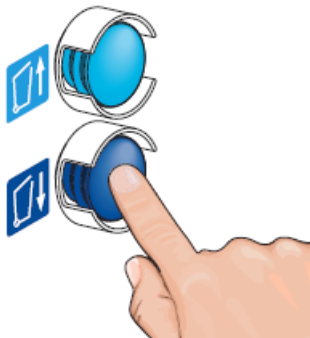

or

Press the light blue UP button to raise the lifting chair.



3. Solve the reason that caused the emergency stop.
4. If necessary, remove the bin / container from the bin lift system.
The bin lift system is ready for use.







2.4 Safety signs

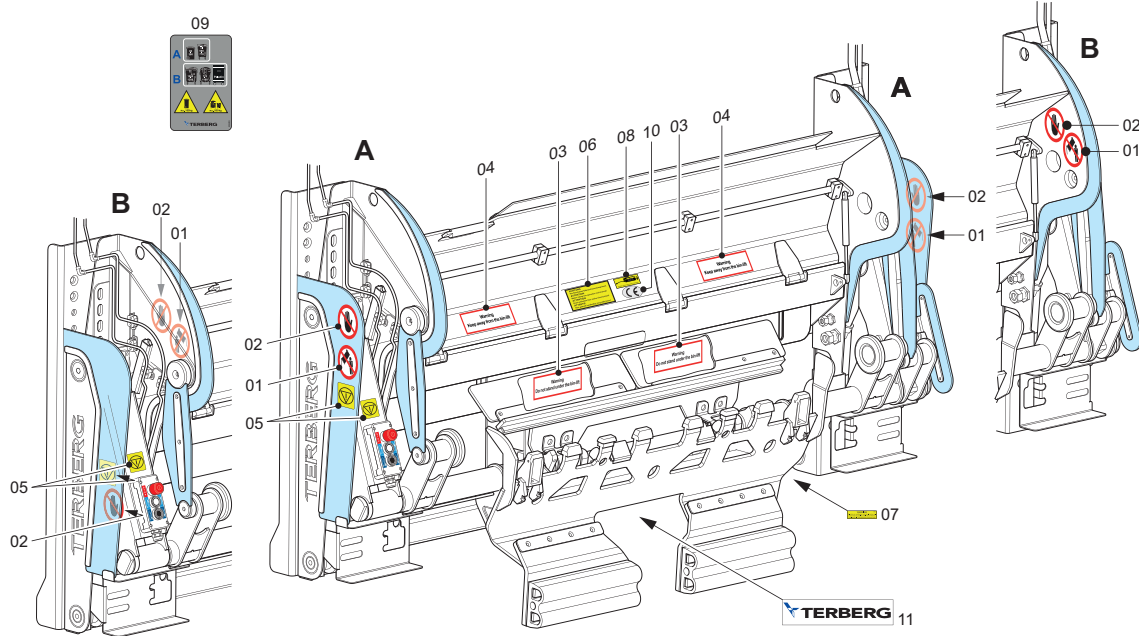

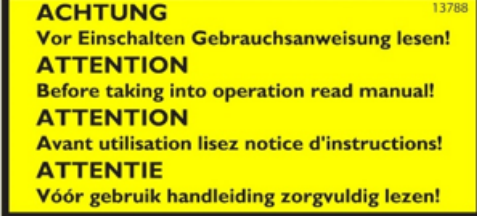

NOTE

The place of the stickers and decals can be different. This depends on the configuration of your OMNITRADE (e).

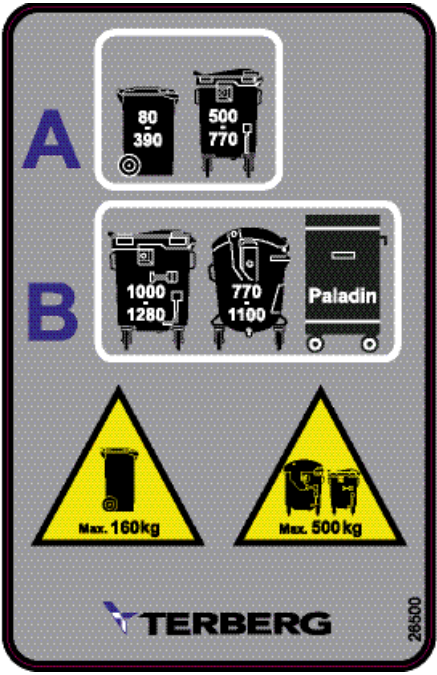

| | |
|---|--|
|  |  |
| <p>1. Do not stand under the bin lift</p> | <p>2. Keep away from the bin lift</p> |
|  |  |
| <p>3. Warning</p> | <p>4. Warning</p> |
|  |  |
| <p>5. Emergency stop</p> | <p>6. Read the manual</p> |
|  |  |

| | |
|--|---|
| 7. Do not alter anything | 8. Grease weekly |
|  <p>The diagram shows two categories of bins: A (80/390 and 500/770) and B (1000/1280, 770/1100, and Paladin). It also includes two yellow warning triangles for maximum weights: Max. 160kg and Max. 500kg. The Terberg logo and the number 28500 are at the bottom.</p> |  <p>The markings include the CE mark in a circle and the UKCA CE mark in a rectangle.</p> |
| 9. Maximum weight bins and containers | 10. CE-marking (EU) - UKCA (UK) |
| |  |
| | 11. Terberg logo |

3 Bin lift operation

3.1 Operator panel

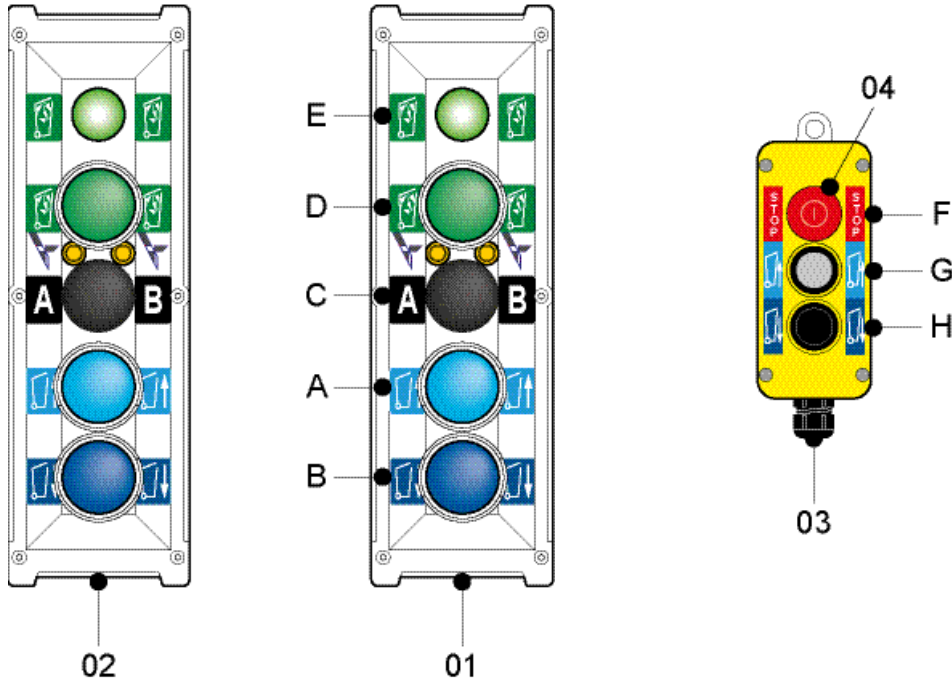

01/02 Button control station R/H or L/H side (A second control station is an option)

03 Button control station container pick-up

04 Emergency stop

A Push button UP

B Push button DOWN

C Push button catcher bar (with LED indicators)

D Push button green SMT (Single Man Trade 4-wheel container)

E SMT check light green

F Emergency stop button

G Push button LIFT container

H Push button DOWN

3.2 Warning and tips



NOTE

Before you start to use the bin lift system, read the operating instructions.

**CAUTION**

When the bin lift system is in operation, do not reach into the lifting system

**WARNING**

Never use the bin lift system as a seat.

- It is forbidden to assist the lift of the bin lift system manually, or by using extra equipment such as a crane or forklift truck.
- Lifting capacity see chapter "Safety" on page 9.
- Overweight bins / containers should be removed from the bin lift system.
- Do not remove the bin / container before the bin lift has come to a standstill.
- Always approach the bin lift forwards with stretched-out arms, even when removing the bin / container.
- You will be working where traffic is present, do not endanger yourself or other road users. Place empty bins/containers where they do not cause any danger to other road users.
- When you are working with the bin lift system do not wear any loose hanging clothing or jewelry.
- Loading is teamwork. Before commencing the run discuss and agree with your colleagues how to act in particular situations such as stopping, driving away, etc.
- Make sure that you are visible to the driver of the refuse collection vehicle when it is reversing.
- It is forbidden to stand on the foot boards while the refuse collection vehicle is reversing.

3.3 Daily checks

Before you start to work, you must check the bin lift system for the following points:

- Check that no oil loss has occurred.
- Look to see if there are any foreign objects (branches, twigs, plastic bags, etc.) in the bin lift system that could hinder its operation.
- Operation of the controls
- Check the operation of all the controls by performing all the possible actions with empty bins / containers:
 - Emergency stop button
 - Catcher bar settings:
Put the catcherbar in Position A (working position) and in Position B.
 - Hopper plate operation / locking
 - Start sensors and 4-wheel recognition.

Footboards (optional)

- Check the operation of the foot boards.
- Check the mounting of the foot boards.

3.4 Loading bags and / or bulky waste



To make it easier to throw in bags and / or bulky waste, you can lower the throw-in height of the bin lift.

1. Before you open the hopper plate, lower the bin lift.
2. Unlock the hopper plate:
 - a. press down the handle A on the L/H side.
 - b. simultaneously rotate the hopper plate all the way down.

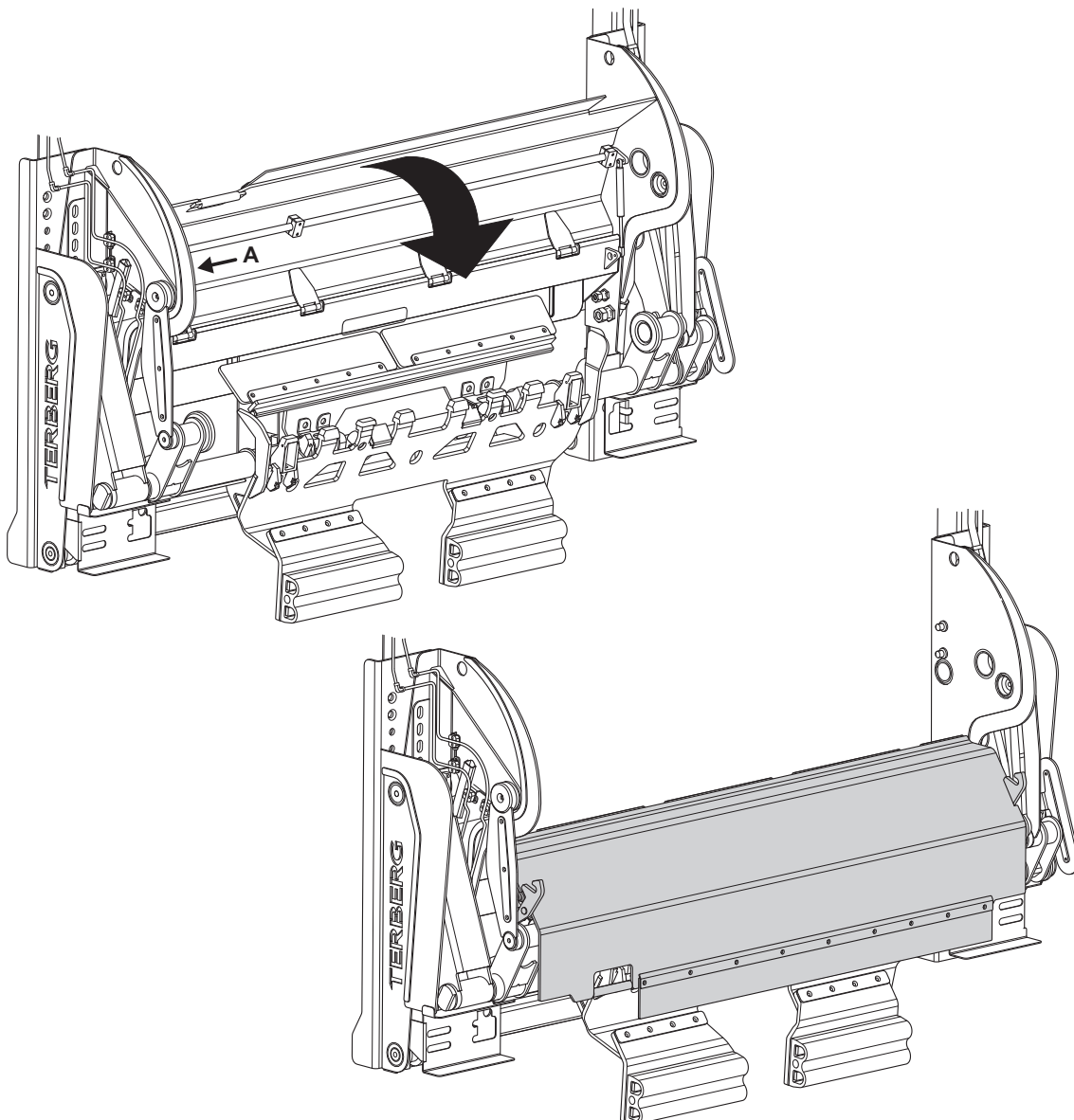

3.5 Loading with the pick-up comb - 2 wheel bins

Contents 80 to 39 litres



According to BS EN 840-1

1. Check that the hopper plate is closed
2. Switch on the refuse collection vehicle compactor system.
3. Optionally, if there are foot boards, fold them down.
4. Check the catcher bar.

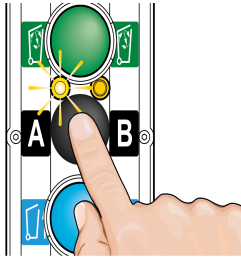

- The catcher bar must be in position A, the working condition.
- The yellow LED indicator (left) must be active.



NOTE

Optionally, the bin lift can be equipped with a function that sends the catcherbar automatically to Position A when presented with a mini-container.

5. Roll the bin against the pick-up comb.



CAUTION

Make sure that the bin is positioned correctly on the pick-up comb.

6. Empty the bin.

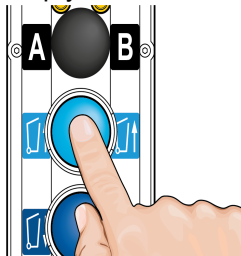

Press the light blue UP button to raise and empty the bin. You find the button on either side of the bin lift.

7. Remove the bin.

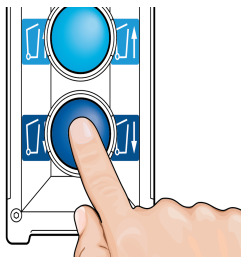

- a. Press the dark blue DOWN button to lower the bin.
- b. Remove the bin as soon as the wheels touch the ground.

Shake function

If refuse gets stuck in the bin, you use the shake function.

1. Keep the light blue UP button pressed once the bin is in tilting position.

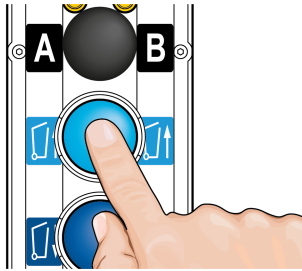

The bin now automatically shakes five times.



NOTE

Only give an extra shake when you must. Shaking takes time and causes extra noise for the surrounding area.

Button control station for bin take-up

On the L/H or R/H tilt arm you find a button control station for limited raising and lowering of the pick-up comb.

1. Roll the bin against the pick-up comb.



CAUTION

Make sure that the bin is positioned correctly on the pick-up comb.

2. Press the UP button of the bin take-up control station.

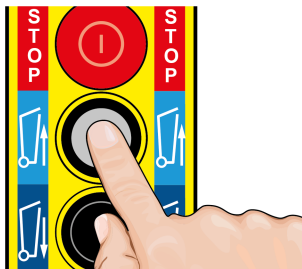

The bin is picked up.

3. Go to the button control station on the L/H or R/H side of the bin lift.
4. Empty the bin.

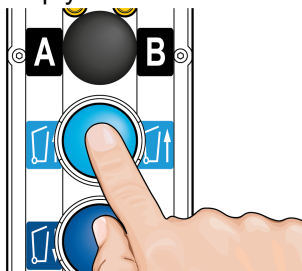

Press the light blue UP button to raise and empty the bin. You find the button on either side of the bin lift.

5. Remove the bin.

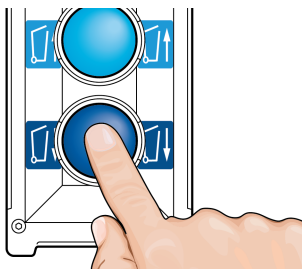

- a. Press the dark blue DOWN button to lower the bin.
- b. Remove the bin as soon as the wheels touch the ground.

3.6 Loading with the pick-up comb - 4 wheel containers

with a ROLL top
contents 770 - 1100 litres

with a FLAT lid
contents 500 to 1209 litres

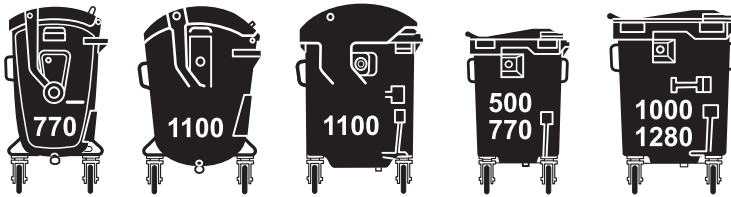

The bin lift is equipped with automatic 4-wheel container recognition. When you roll a container against the pick-up comb, the catcher bar goes automatically to Position B (folded away).

1. Check that the hopper plate is closed
2. Switch on the refuse collection vehicle compactor system.
3. Optionally, if there are foot boards, fold them down.
4. Put the catcher bar in the correct position. Use the black button.

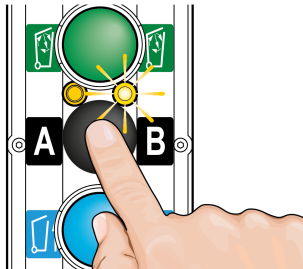

For containers with a flat lid of 500 to 770 litres the catcher bar must be in Position **A**. The yellow LED indicator on the L/H side must be active.

For flat-lid containers with a capacity of 1000 to 1280 litres and for roll-top containers, the catcher bar must be in Position **B**.

5. Roll the container against the pick-up comb.



CAUTION

Make sure that the bin is positioned correctly on the pick-up comb.

6. Empty the bin.

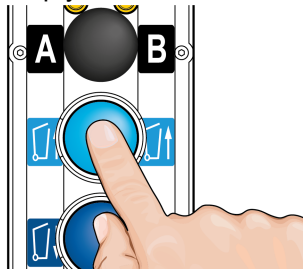

Press the light blue UP button to raise and empty the bin. You find the button on either side of the bin lift.

7. Remove the bin.

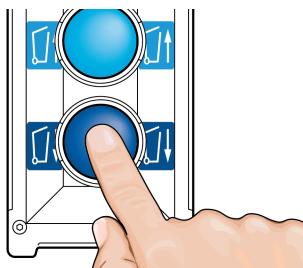

- a. Press the dark blue DOWN button to lower the bin.
- b. Remove the bin as soon as the wheels touch the ground.

Shake function (compostable waste)

If refuse gets stuck in the container, use the shake function.

1. Keep the light blue UP button pressed once the bin is in tilting position.

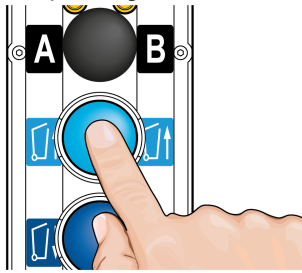

The bin now automatically shakes five times.



NOTE

Only give an extra shake when you must. Shaking takes time and causes extra noise for the surrounding area.

Button control station for container take-up

On the L/H tilt arm you find a button control station for limited raising and lowering of the pick-up comb.

1. Roll the bin against the pick-up comb.



CAUTION

Make sure that the bin is positioned correctly on the pick-up comb.

2. Press the UP button of the bin take-up control station.

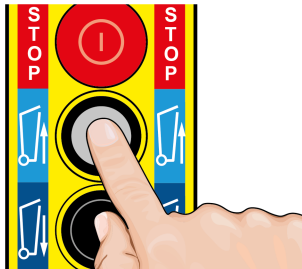

The bin is picked up.

3. Empty the bin.

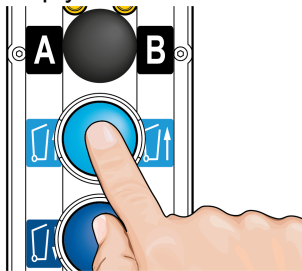

Press the light blue UP button to raise and empty the bin. You find the button on either side of the bin lift.

4. Remove the bin.
 - a. Press the dark blue DOWN button to lower the bin.
 - b. Remove the bin as soon as the wheels touch the ground.

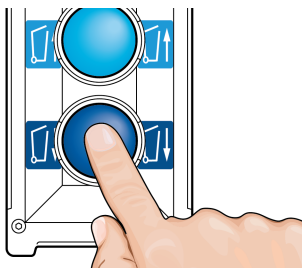

3.6.1 Single Man Trade (SMT)

SMT is a (semi-) automatic function that makes it possible for one person to empty 4-wheel containers or multiple 2-wheel bins.



NOTE

One man operation is only possible when 4-wheel containers are lifted with the pick-up comb.

1. Make sure that the pick-up arms are folded in.
2. Check that the hopper plate is closed.
3. Start SMT.

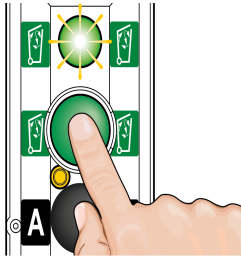

Press the green SMT button. The green indicator light flashes.

4. For **4-wheel containers**
 - a. Roll the container against the pick-up comb. The container is automatically lifted some 20 cm.
 - b. The bin lift waits for the UP / DOW button on the L/H or R/H control station to be activated.
 - c. Put the catcherbar in the correct position.

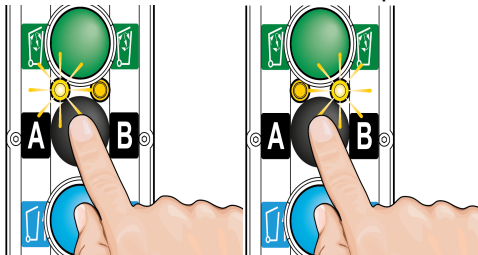

- d. For containers with a flat lid of 500 to 770 litres the catcher bar must be in Position **A**. The yellow LED indicator on the L/H side must be active.
- e. For flat-lid containers with a capacity of 1000 to 1280 litres and for roll-top containers, the catcher bar must be in Position **B**.
- f. Empty the container

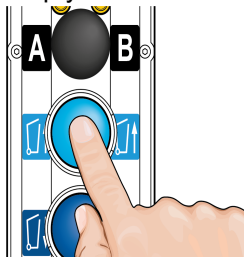

Press the light blue UP button to raise and empty the container. You find the button on either side of the bin lift.

g. Remove the container

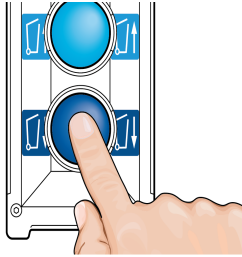

- i. Press the dark blue DOWN button.
The container lowers to the ground/
- ii. Remove the container from the bin lift as soon as the wheels touch the ground.

5. For **2-wheel bins**

- a. Roll a bin left or right against the pick-up comb.
The bin lift waits a few seconds to see if a second bin is rolled next to the first one. If this does not happen, the bin is automatically lifted some 20 cm.
- b. Present a second bin and it will be automatically raised.

6. Check the catcher bar.

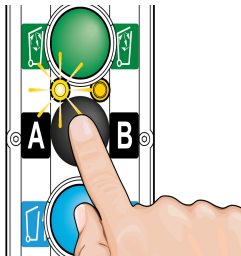

- The catcher bar must be in position A, the working condition.
 - The yellow LED indicator (left) must be active.
- a. Roll the bin against the pick-up comb.
 - b. Empty the bin.

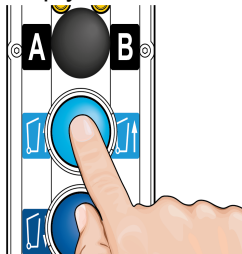

Press the light blue UP button to raise and empty the bin. You find the button on either side of the bin lift.

c. Remove the bin.

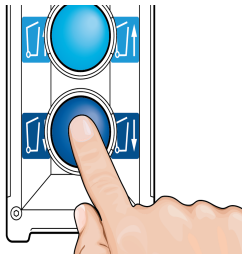

- d. Press the dark blue DOWN button to lower the bin.
- e. Remove the bin as soon as the wheels touch the ground.

3.7 Loading with the pick-up arms(optional)

with a ROLL top
contents 770 - 1100 litres

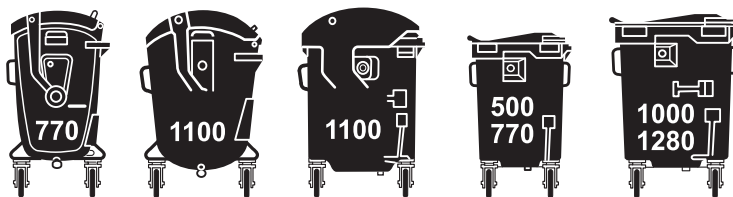

with a FLAT lid
contents 500 to 1209 litres

You can optionally fit the OMNITRADE (e) with pick-up arms.



NOTE

When the pick-up arms are used, SMT is no longer possible.

1. Check that the hopper plate is closed.
2. Switch on the refuse collection vehicle compactor body.
3. Fold the foot boards down.
4. Fold out both pick-up arms
5. Put the catcher bar in the correct position. Use the black button.

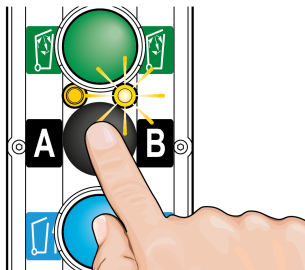

For containers with a flat lid of 500 to 770 litres the catcher bar must be in Position **A**. The yellow LED indicator on the L/H side must be active.

For flat-lid containers with a capacity of 1000 to 1280 litres and for roll-top containers, the catcher bar must be in Position **B**.

6. Roll the container straight between the pick-up arms.
7. Bring the pick-up heads to the correct height.

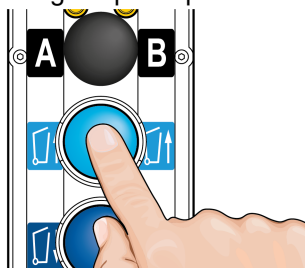

Use the light blue UP button to raise both pick-up arms until the pick-up heads are level with the trunnions of the container.



CAUTION

Take great care that the container's trunnions insert firmly into both the pick-up heads of the pick-up arms.

8. Empty the bin.

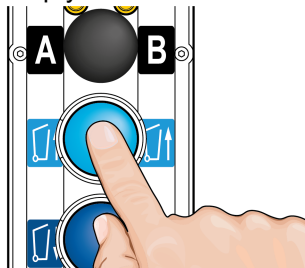

Press the light blue UP button to raise and empty the bin. You find the button on either side of the bin lift.

9. Remove the bin.

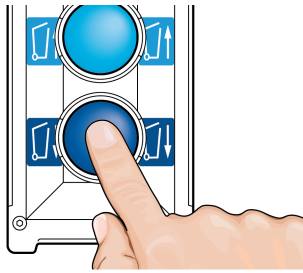

- a. Press the dark blue DOWN button to lower the bin.
- b. Remove the bin as soon as the wheels touch the ground.

Trunnions stuck in pick-up heads



NOTE

On an uneven road surface the trunnions of the container may get stuck in the top position of the pick-up heads.

Procedure:

1. Use the light blue UP button to raise the container slightly. Stop when the wheels are clear of the ground.
2. Put the container backwards so that the trunnions of the container are in the lower position of the pick-up heads.
3. Let the container descend.



CAUTION

Ensure that your fingers do not become trapped when folding the pick-up arms.

3.8 Travel height and foot boards

Footboards and handle bars

The bin lift can optionally be fitted with foot boards and handle bars. The fixed handle bars - two brackets on either side - are used in three situations. In each of these situations, the foot boards must be in the correct position.

- **Transport**
Footboards folded up
- **Loading**
Footboards folded down
- **Riding**
Footboards folded down.
Keep your hands as shown in the picture below.

If someone is standing on the foot board:

- Reversing is forbidden.
- The refuse collection vehicle may not be driven at more than 30 kilometers per hour (19 mph)
- The compactor should not run in full automatic mode.

Throwing in waste manually

Throw large, heavy objects across the width of the compactor body to prevent damage to the bin lift system.

Obstacles or uneven surfaces

When you drive over large obstacles or uneven terrain, it is important to place the foot boards in the transport position and tilt the bin lift up for adequate ground clearance.

**WARNING**

Never operate the bin lift when the refuse collection vehicle is travelling along or in reverse gear.

**CAUTION**

*Never stand on other parts of the bin lift.
Never use parts of the bin lift as a seat.*

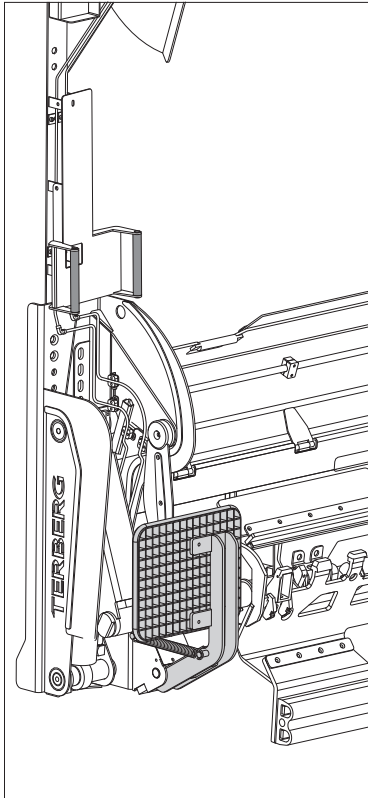
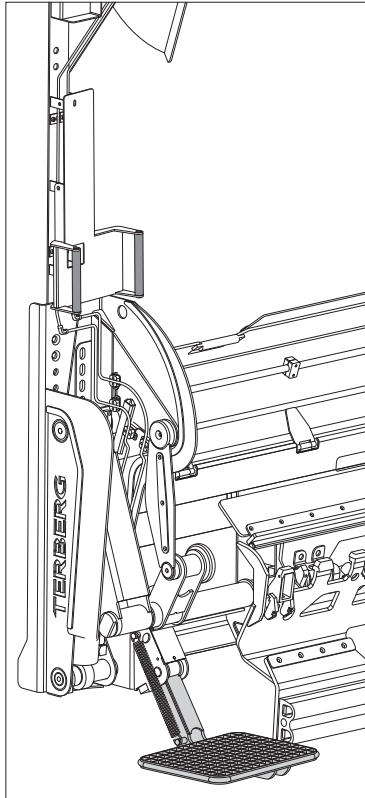
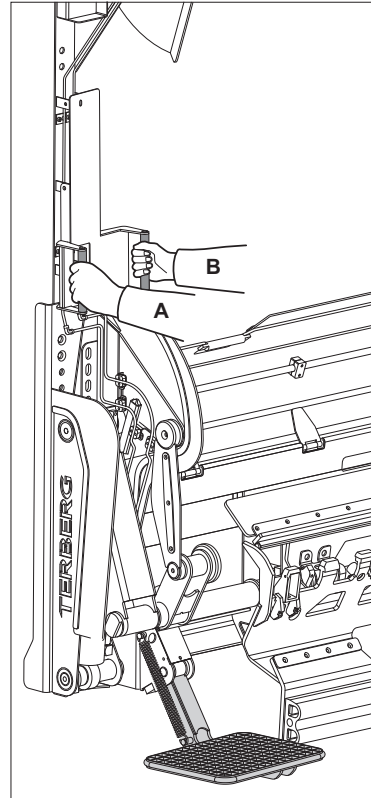
Transport**Loading****Riding**

4 Maintenance and cleaning

4.1 General maintenance

Before you start with maintenance, cleaning or repair work, take the following into account:

- Apply the handbrake of the refuse collection vehicle.
- Press the emergency button.
- Secure the tilt frame against sagging (hoist, struts, etc.) before you work on it.
- Never alter or remove any of the installed safety features.
- Always adhere to the maintenance interval, specified by Terberg Machines B.V.

4.2 Daily maintenance

We recommend to clean the bin lift system at the end of every working day.



CAUTION

Before you start to clean, switch off the drive of the refuse collection vehicle.



CAUTION

Do not stand under the tilt frame while cleaning the bin lift system.

- Clean the bin lift system with a high-pressure cleaner.
- Do not spray directly on to electrical components, control stations or decals.
- Keep some 30-40 cm distance between the spray lance and the bin lift.
- We strongly discourage the use of pressure cleaners with rotating or pulsating nozzles.
- When grease has been cleaned from moving parts, re-fill these points with grease before you take them back into service.



CAUTION

Always wear safety goggles when you clean the bin lift with a high pressure cleaner

- Check if the foot boards and the handle bars of the bin lift system are undamaged, function properly and are firmly mounted.

4.3 Weekly maintenance

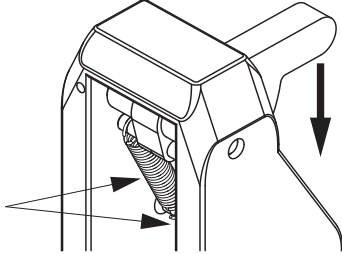
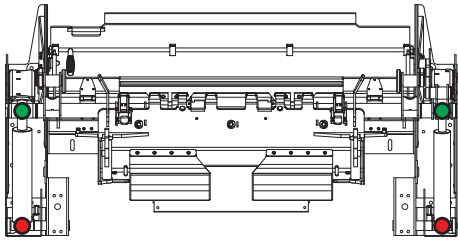
| Bin lift part | Actions |
|------------------------------------|---|
| Operation of the controls | <p>Check the operation of all the controls by running the bin lift through all possible operations with empty bins /containers</p> <ul style="list-style-type: none"> - Emergency stop switch. - Shake function. - Catcherbar setting; put the catcherbar in Position A (working position) and in Position B. |
| Hopper plate | <p>Check that the hopper plate turns smoothly and that the locking is secure.</p> <p>Check the Vulcolan strip and replace it if it is deformed or cracked.</p> <p>Check the operation of the hopper plate switch.</p> |
| Sensors | <p>Check the operation of the start sensors</p> <p>Check the 4-wheel recognition sensor.</p> |
| Decals | <p>Replace damaged safety instructions or instruction decals immediately.</p> |
| Container security switch (option) | <p>Check the spring action and the springs of the container security switch "if present".</p>  |
| DIN pick-up arms (option) | <p>Check that the closure lips close in the tilted position.</p> |
| Lubricating the bin lift system |  <p>The bin lift system has four grease nipples on the lift cylinders.</p> <p>The lower grease nipples (red) can be reached with the tilt frame in the resting position.</p> <p>The upper (green) in this case with the tilt frame in the tip position.</p> <ol style="list-style-type: none"> 1. Secure the tilt frame against sagging (hoist, struts, etc.). 2. Remove the red protective caps and clean the grease nipples. 3. Keep adding grease until you see fresh grease between the pivots. Only use approved acid-free types of grease that do not harm the bearings, such as Multifak EP2 Texaco (or equivalent). |

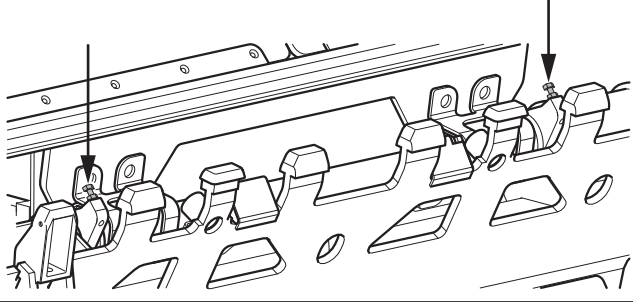
| Bin lift part | Actions |
|-------------------|--|
| Visual inspection | <p data-bbox="386 241 1114 277">Check that the teeth of the pick-up comb are aligned correctly.</p>  |
| | <p data-bbox="386 582 1235 618">Check the security and condition of the rubber stops and warning edges.</p> |
| | <p data-bbox="386 622 963 658">Check the bin lift for any faulty or damaged parts.</p> |
| | <p data-bbox="386 663 772 698">Check that there are no oil leaks.</p> |
| | <p data-bbox="386 703 740 739">Check the wiring for damage.</p> |

4.4 Six-weekly maintenance



NOTE

First carry out the weekly maintenance

| Bin lift part | Action |
|---------------------------------|--|
| Container locking | <p>Check the clamp gap between the pick-up comb and the clamping plate (see drawing below). This must be done with the pick-up comb in the upper position. Measure at several places!</p> <p>The clamp gap can be adjusted by using the two adjustment bolts (see the drawing, left).</p> |
| Proximity switches (if present) | Check the adjustment. |
| DIN pick-up arms (option) | <p>Check the springs.</p> <p>Check the distance between the pick-up arms, at the pick-up heads, when they are folded out. This size must be 1265 ± 5 mm and should also be centred to the centre line of the machine. The distance can be corrected by screwing the stop bolts in or out.</p> |
| Footboards (option) | <p>Check the springs.</p> <p>As an option, the foot boards can be fitted with sensors by the body manufacturer. In this case, check the functioning in accordance with the instructions and requirements provided by the body manufacturer.</p> |



CAUTION

Rectify any identified faults before the bin lift is put into service.

4.5 Annual maintenance



NOTE

First carry out the weekly and six-weekly maintenance

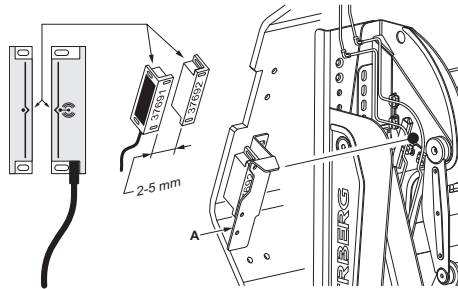
| Bin lift part | Action |
|--------------------------------------|---|
| Mounting of bin lift | Re-tighten all the mounting bolts of the bin lift, including: <ul style="list-style-type: none"> - The mounting of the bin lift system onto the refuse collection vehicle or mounting frame. - The bin lift foot boards. |
| Pick-up teeth. | Check the pick-up teeth for wear. |
| Bin lift cycle time | Check the cycle time of the bin lift. This may not be less than 10 seconds (excluding the dwell time). The time between pick-up to the tip position should be at least 5 seconds (measured with an empty 240 litre bin). |
| Working pressure hydraulic system | Check the working pressure of the hydraulic system. The working pressure is set to 130 bar (180 bar for the Middle East). The bin lift system is rated for a lifting capacity of no more than 750 kg. <ul style="list-style-type: none"> - The lifting pressure can be measured via measuring point M3 (see "Hydraulics" op pagina 59). Reading: 130 bar (180 bar for the Middle East). - The lowering pressure can be measured at measuring point M4 (see "Hydraulics" op pagina 59). Reading: 40 bar (75 bar for the Middle East). |
| Hopper plate switch | Check the opening between the transmitter (37692) and receiver (37691). This opening should be between 2 and 5 mm (see drawing). This can be corrected by moving the mounting bracket (A) of the transmitter slightly. <div data-bbox="379 1146 839 1433" data-label="Image">  </div> |
| Alignment markings on rear / opening | Take note of the alignment markings of the transmitter and receiver during any installation work. |
| Hydraulic hoses | The hydraulic hoses must be replaced after four years' use. This must be done at the latest six years after the production date (indicated on the hose ferrule). |
| Electrical wiring | Check the electrical wiring, electrical connections and control stations for the entry of moisture. |

4.6 Six monthly maintenance Omnitrade e

| Bin lift part | Action |
|------------------------|--|
| Batteries | Check the level of the electrolyte |
| Electrical connections | Check the electrical connections. Clean them if necessary. |

4.7 Two yearly maintenance Omnitrade e

| Bin lift part | Action |
|--------------------------------|--|
| Condition of batteries | Test the batteries. Replace if needed. |
| Hydraulic oil | Change the hydraulic oil; Shell Tellus S2VX 32. Do this before the date shown on the sticker. You find the sticker inside the hydraulic box. |
| Seal ring drain plug (17629)* | Replace the seal ring (Multi seal). Do this before the date shown on the sticker. You find the sticker inside the hydraulic box. |
| Oil filter (18968)* | Replace the oil filter. Do this before the date shown on the sticker. You find the sticker inside the hydraulic box. |
| Filler cap / breather (26986)* | Replace the filler cap / breather. Do this before the date shown on the sticker. You find the sticker inside the hydraulic box. |

4.8 Four yearly maintenance Omnitrade e

| Bin lift part | Action |
|-----------------|---|
| Hydraulic hoses | Replace the hydraulic hoses after four years. You must replace the hydraulic hoses at the latest six years after the production date. You find this date on the coupling housing. |

4.9 Troubleshooting

| Error | Check |
|--|---|
| There is not enough lifting force. | Check the oil supply from the compactor body, check the working pressure. |
| Bin lift slows down. | Check the oil supply from the compactor body. |
| Oil temperature exceeds 75°C. | Check the maximum oil supply from the compactor body. |
| Bin lift runs askew. | Check cylinders and hoses for internal and external leakage. Perform a position sensor calibration in which the UP button is held in position for at least two minutes. With this, the cylinders are hydraulically levelled |
| The bin lift does not go fully up or down. | Check the error blink code. Check the position sensor above the right liftcylinder. Calibrate the position sensor |
| Bin lift stops halfway through lifting. | Check the error blink code. Check that the hopper plate is closed properly and that the hopper plate switch is active. |

| Error | Check |
|------------------------------------|--|
| Bin lift does not move at all. | Check the power supply, check oil supply, check the error blink code. Is there someone on the foot board? Is the hopper plate closed? Check the emergency stop on the bin lift and body. |
| Bin lift releases bins/containers. | Check that the container clamp mechanism is free of refuse or other obstructions and is correctly adjusted.. |

4.10 Fault blink code

If a fault (problem) occurs, you will be warned by the flashing of the R/H yellow indicator LED (B). You deduct the type of problem from the blink frequency.

- If the yellow LED indicator was already on (catcherbar in Position B), this will first go OUT and then go ON for one second (start signal). This is followed by a two-second pause.
- The LED will now blink a number of times in succession followed by a pause. The number indicates the fault code, see table (right).
- If there are multiple fault codes, they are displayed in succession. The following fault code begins again with a start signal of one second.
- The blinking of a fault code is repeated until the problem is solved.
- The LED blinks 10 flashes for a '0' ,

Frequency:

Start signal 1 second (A)

Pause 2 seconds (B)

LED ON 0,1 seconds (1)

LED OFF 0,4 seconds (0)

In the example below you see a five pulse fault code (C) which could be followed by a next fault code (D). It signifies the fault code 5.

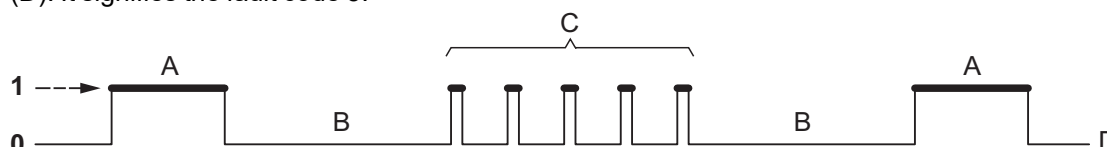

Examples:

45 flashes as follows:

Start pulse - pause - 4 flashes - pause - 5 flashes - repeat until problem is solved.

20 flashes as follows:

Start pulse - pause - 2 flashes - pause - 10 flashes - repeat until problem is solved.

4.11 Open the hydraulic system

The OMNITRADE (e) bin lift has a special master/slave synchronisation system. That means that the two lift cylinders are interconnected for perfect synchronisation.

When opening the hydraulic system - for example, to replace the hoses - serious consideration should be given to this.

- Try to lose as little oil as possible while replacing the components.
- Support the bin lift and make absolutely sure that the bin lift does not move during work.

The cylinders in the OMNITRADE (e)bin lift are fitted with special internal automatic levelling valves.

These can remove any residual air if necessary.

1. Keep the bin lift in the upper position for at least 2 minutes under full working pressure.
2. Put the bin lift temporarily into the 'Position sensor' calibration mode and hold the UP button for two minutes.



After carrying out work, always check that the system is synchronised and in alignment. Only then put it back into operation.

4.12 Alarm codes

| Number | Note: | Displayed text | Event description |
|--------|------------------------|------------------------------|--|
| 1 | | EMERGENCY STOP | Emergency stop signal is active. Check emergency stop buttons on the bin lift and refuse body. |
| 2 | | TRUCK IN REVERSE | Reverse gear signal is active. A reverse gear signal is produced on the refuse body/ truck chassis. Put the gearbox into neutral gear if you want to use it. |
| 7 | | ADJUST ZERO WEIGHING SYSTEM | Static zeroing request for weighing systems (TMDW9004/TMDW9009/TMDW8010) Normal message during start up in the morning. Please perform a zero adjust sequence by holding down the R/H up and down button simultaneously in domestic mode for a few seconds until the bin lift moves up automatically. |
| 8 | | FOOTBOARD STOP | One or more foot boards occupied. The bin lift receives this signal from the refuse body. The bin lift should stop any movement. Make sure nobody is on the foot boards when working with the bin lift. If there is nobody on the foot board check foot boards, foot board sensors and signals from the refuse body. |
| 9 | | SETUP NOT READY | Valve, position calibration not ready and/or serial number not set. Check calibration of valves, position sensor and if serial number is set. |
| 10 | BL lifter | CONTROL STATION ERROR ON ARM | Probably caused by a button which was active after a power up or emergency stop situation. Check if all buttons are free (not active), and for a possible short circuit in wiring. |
| 11 | | HOPPER PLATE SWITCH | The hopper plate door is open, the bin lift is ready for hand loading of bags only. Hopper plate line 1 or Hopper plate line 2 is low. This error means that the hopper plate door is not closed. Close the hopper plate door. If this message is displayed, even with the hopper plate door closed, please check the functionality and alignment from the hopper plate door sensor. |
| 12 | Left hand side lifter | ERROR CYC.START SENSOR N1 | An object is detected by the N1 start sensor much longer than normal. This can occur if a bin is not taken away from the bin lift once it has been put down after a normal emptying cycle. If this message occurs with no bin or object in front of the sensor or pedal arm check the sensor and cable. |
| 13 | Right hand side lifter | ERROR CYC.START SENSOR N1 | An object is detected by the N1 start sensor much longer than normal. This can occur if a bin is not taken away from the bin lift once it has been put down after a normal emptying cycle. If this message occurs with no bin or object in front of the sensor or pedal arm check the sensor and cable. |

| Number | Note: | Displayed text | Event description |
|--------|------------------------|-----------------------------|---|
| 14 | | RCV NOT READY | The compactor/RCV is not producing a “ready to work” signal on the 16 pin plug connections The bin lift is not allowed to move or ask for hydraulic power from the refuse compactor. Find out why the bin lift does not receive an “RCV ready” signal from the refuse body. Make sure the Refuse body controller is OK. Make sure the gearbox is in Neutral. Make sure the PTO is active. |
| 15 | | HOPPERPLATE SENSOR ERROR | Sensor is detected as defect. Check wiring hopper plate sensor and/or replace sensor. |
| 16 | | FOOTBOARD NOT DOWN | Foot board detected as not down. If foot board is down check wiring and foot board sensors. |
| 17 | Left hand side lifter | LH N6 CONTAINER SWITCH ON | N6 comb switch is switched on longer than x milliseconds without start sensor N1 is detected a object. The switch stays active , check the comb sensor and wiring. |
| 18 | Left hand side lifter | LH N1 START SWITCH ON | N1 start sensor is detecting an object longer than x milliseconds without detecting a bin on comb with N6 sensor. The object is presented in range of N1 or N1 is defect. Remove object and/or check the start sensor. |
| 19 | BL lifter | POSITION SENSOR CALIBRATION | Lifter in position sensor calibration mode. |
| 20 | BL lifter | VDH9013 INIT BUSY | VDH9013 software , initialization of weighing computer is busy. Not possible to lift , wait till the initialization of the weighing computer is ready. |
| 21 | Left hand side lifter | ERROR COMB SENSOR N6 | Message if N6 comb switch is not switched on within x milliseconds after start sensor N1 is detected. The bin is presented wrongly. Present the bin in a normal way. Check the comb sensor. |
| 22 | Right hand side lifter | ERROR COMB SENSOR N6 | Message if N6 comb switch is not switched on within x milliseconds after start sensor N1 is detected. The bin is presented wrong, please present the bin in a normal way. <ul style="list-style-type: none"> • Check the comb sensor. |

| Number | Note: | Displayed text | Event description |
|--------|---------------|--|--|
| 25 | | WAIT FOR PACKER | <p>The RCV and bin lift are both equipped with an anti-collision system. This prevents the compactor to pack/collide with the bin or bin lids when a trade bin is inside the compacting area.</p> <p>You see this message when the compactor is moving down towards the bin lift, or is stopped in a possible collision situation. The bin lift stops lifting/tipping until the compacting system has reported to be out of the collision zone.</p> <ul style="list-style-type: none"> • Start the compactor. Make sure the compacting mechanism is out of the collision zone before emptying a trade bin. • Check the signals from the refuse body to the compactor |
| 26 | BL lifter | MOTOR CONTROLLER ERROR | See document : MotorControllerCANInterfaceV100.doc For Electric lifters with CAN to CAN interface only. The right hand motor controller has detected one or more errors. |
| 27 | TRUCK IN GEAR | Drive gear is active and the up/down buttons are blocked | info message |
| 28 | | LOW VOLTAGE START VEHICLE | <p>For Electric lifters: The detected battery voltage has been too low during a certain maximum amount of bins emptied. There is something wrong with the battery or the truck is not charging the battery anymore. The bin lift will stop working to prevent damage to the battery and to make sure the truck engine can still start.</p> <ul style="list-style-type: none"> • Charge the batteries by starting the engine. • Check the power supply or batteries. |
| 29 | BL lifter | ERROR POSITION SENSOR | <p>This error can be generated by more than one fault and is a global generated position sensor error for the left hand lifting chair. When the bin is removed the error will be reset.</p> <ul style="list-style-type: none"> • Check for mechanical axial and radial play from the position sensors or adjoined bearings. • Check the position sensor(s). • Check the cables from the position sensors. • Check the analogue values from the position sensors. (analogue input 00.0 and 00.1 always higher than 100 , lower than 900) • Recalibrate the position sensors. |

| Number | Note: | Displayed text | Event description |
|--------|------------------------------|--------------------------|---|
| 31 | Left hand side domestic bin | IDENT STOP | <p>A weighing or identification system gives a Stop signal to the left bin lift.</p> <p>The xxx nr. Explains the following error.</p> <p>If an external so no Terberg VDH or Datamanager TMID7009 is mounted: Only message IDENT STOP L/H is displayed.</p> <p>VDH or data-manager TMID7009: xx: LIST STOP xxx : block lifter tag is listed for stop xx: NO TAG xxx : block lifter no tag found by identification system xx: READER TIME OUT : block lifter no ready received on check id stop height</p> |
| 32 | Right hand side domestic bin | IDENT STOP | <p>A Stop signal is given from a weighing or identification system to stop the right bin lift.</p> <p>The xxx nr. explains the error. If an external so no Terberg VDH or data-manager TMID7009 is mounted: Only message IDENT STOP R/H is displayed.</p> <p>VDH or data-manager TMID7009: xx: LIST STOP xxx : block lifter tag is listed for stop xx: NO TAG xxx : block lifter no tag found by identification system xx: READER TIME OUT : block lifter no ready received on check id stop height</p> |
| 33 | 4W/Trade bin | IDENT STOP | <p>A Stop signal is given from a weighing or identification system to stop the left, right or trade bin lift.</p> <p>The xxx nr. explains the error.</p> <p>If an external so no Terberg VDH or data-manager TMID7009 is mounted: Only message IDENT STOP 4W is displayed.</p> <p>VDH or data-manager TMID7009: xx: LIST STOP xxx : block lifter tag is listed for stop xx: NO TAG xxx : block lifter no tag found by identification system xx: READER TIME OUT : block lifter not ready, received on check id stop height</p> |
| 34 | | WEIGHING SYSTEM TIME OUT | <p>Weighing system was too late with calculating weight results.</p> |
| 35 | Left hand side domestic bin | BIN TOO HEAVY | <p>An optionally or externally mounted Weighing system sends out a command to stop the bin lift because the bin is too heavy. This Stop signal can be given over conventional identification signals or over Clean Open CAN connection. The bin is too heavy, remove the bin. Check the weighing system.</p> |

| Number | Note: | Displayed text | Event description |
|--------|------------------------------|-----------------------------|---|
| 36 | Right hand side domestic bin | BIN TOO HEAVY | An optionally or externally mounted Weighing system sends out a command to stop the bin lift because the bin is too heavy. This Stop signal can be given over conventional identification signals or over Clean Open CAN connection. The bin is too heavy, remove the bin. Check the weighing system. |
| 37 | 4W/Trade bin | BIN TOO HEAVY | An optionally or externally mounted Weighing system sends out a command to stop the bin lift because the bin is too heavy. This Stop signal can be given over conventional identification signals or over Clean Open CAN bus connection. The bin is too heavy, remove the bin. Check the weighing system. |
| 38 | | TRUCK / BODY MAXIMUM WEIGHT | An external (under body) Weighing system or the bin lifts controller calculated the max. allowed total body weight has been reached. The truck is at its maximum allowed vehicle weight. Empty the truck |
| 39 | Left hand side lifter | STOP IN WEIGHING | Weighing systems TMDW9009/TMDW8010/VDH9013. This Signal is for bin lifts with weighing systems only: The bin lifts controller detected the left hand bin lift has been stopped inside the weighing window. Therefore the Weighing results will be unreliable. Put the bin down and retry. Do not stop the up or down motion of the bin inside the weighing window. |
| 40 | Right hand side lifter | STOP IN WEIGHING | Weighing systems TMDW9009/TMDW8010/VDH9013. This Signal is for bin lifts with weighing systems only: The bin lifts controller detected the righthand bin lift has been stopped inside the weighing window. Therefore the Weighing results will be unreliable. Put the bin down and retry. Do not stop the up or down motion of the bin inside the weighing window. |
| 41 | | TILT TOO HIGH | This signal is for bin lifts with weighing systems only. The inclination sensor from the Weighing system has detected that the vehicle is positioned on a slope which is too steep to produce a reliable weighing result. Reposition the vehicle on a more level surface. If this message occurs even when the vehicle is on a flat surface, check the inclination sensor or weighing system. |
| 42 | Left hand side domestic bin | WEIGHING SPEED ERROR | Lifter speed was changed inside the weighing window. Check start and stop positions weighing window and the lifter speed settings . |

| Number | Note: | Displayed text | Event description |
|--------|------------------------------|-----------------------------------|--|
| 44 | | DATA STORAGE FAILURE | Identification or weighing system backup memory error. No external storage memory is placed in the identification system or weighing system. For weighing system TMDW9004/TMDW9009/TMDW8010 only: Check if a data card is loaded into the on-board data card reader. Make sure the data card has been setup correctly and format is correct. Check if the data card reader power supply is ok |
| 45 | | NO MEMORY CARD | Weighing or RFID identification system has no memory card. |
| 46 | 4W/Trade bin | WEIGING ZERO ERR TRADE IS ACTIVE | VDH9013 dynamic zeroing activated while the bin lift is in 4W/trade mode. Dynamic zeroing is not possible in 4W state. Switch the bin lift into 2 wheel mode before doing a zero adjust. |
| 47 | 4W/Trade bin | WAIT WEIGHING NOT READY FOR TRADE | Weighing systems :VDH9013/TMDW9009/TMDW9004/TMDW8010 weighing system is busy calculating/ not ready to start a new weighing cycle. Remove bin and wait a few seconds before applying a new bin. If this message is continuously on the screen please check the weighing system |
| 49 | Right hand side domestic bin | WAIT WEIGHING NOT READY | Weighing systems :VDH9013/TMDW9009/TMDW9004/TMDW8010 x side of weighing system is busy calculating/ not ready to start a new weighing cycle. Remove bin and wait a few seconds before offering a new bin. If this is a continuous message check the weighing system. |
| 50 | Right hand side lifter | RH N6 CONTAINER SWITCH ON | Message if N6 comb switch is switched on longer than x milliseconds without start sensor N1 detecting an object. The switch stays active , check the comb sensor and wiring. |
| 51 | Right hand side lifter | RH N1 START SWITCH ON | Message if the N1 start sensor is detecting an object longer than x milliseconds without detecting a bin on comb with N6 sensor. The object is presented in range of N1 or N1 is defect. Remove object and/or check the start sensor. |
| 52 | Left hand side lifter | N11 SENSOR 4 WHEEL BIN ERROR | Message is displayed when N11 trade bin detection sensor input stays active. Message will be reset as soon as input is deactivated. |
| 53 | Right hand side lifter | N11 SENSOR 4 WHEEL BIN ERROR | Message is displayed when N11 trade bin detection sensor input stays active. Message will be reset as soon as input is deactivated. |

| Number | Note: | Displayed text | Event description |
|--------|------------------------------|--------------------------------|---|
| 60 | | CAN BUS ERROR | <p>General Bin lift CAN bus error. A CAN bus error can be caused by the following failures:</p> <ol style="list-style-type: none"> 1. Termination of CAN bus not o.k. 2. A defect CAN cable. 3. One or more CAN devices are broken or cannot be found by the controller 4. Wrong bit rate or CAN settings (at installation only). <p>If a specific CAN devices is not found by the controller this can be displayed as well. Check 120Ω line resistance. Check all CAN related Cables. Contact your Terberg supplier.</p> |
| 61 | | DATA STORAGE FAILURE | <p>Identification or weighing system backup memory error. No external storage memory is placed in the identification system or weighing system. For weighing system TMDW9004/TMDW9009/TMDW8010 only: Check if a data card is loaded into the on-board data card reader. Make sure the data card has been setup correctly and format is correct. Check if the data card reader power supply is ok</p> |
| 62 | Left hand side domestic bin | WEIGHING ERROR L/H CODE : | Weight result |
| 63 | Right hand side domestic bin | WEIGHING ERROR R/H CODE : | Weight result. |
| 64 | 4W/Trade bin | WEIGHING ERROR TRADE BIN CODE: | Weight result |
| 70 | Left hand side domestic bin | NO TAG L/H | RFID system has blocked the lifter, tag was not found on antenna. |
| 71 | Right hand side domestic bin | NO TAG R/H | RFID system has blocked the lifter, tag was not found on antenna. |
| 72 | 4W/Trade bin | NO TAG TRADE | RFID system has blocked the lifter, tag was not found on antenna. |
| 73 | Left hand side domestic bin | ID LIST STOP | RFID system has blocked the lifter, tag was found in blocking list. |

| Number | Note: | Displayed text | Event description |
|--------|------------------------------|------------------------------------|--|
| 74 | Right hand side domestic bin | ID LIST STOP | RFID system has blocked the lifter, tag was found in blocking list. |
| 75 | 4W/Trade bin | DOMESTIC BIN ON COMB STOP | Lifter is in trade mode and detected a 2 wheeled domestic on the comb instead of the expected 4 wheeled trade bin. Move lifter down, remove bin and set lifter in the right mode. |
| 82 | Left hand side lifter | READY DYN ZERO WEIGHING | VDH9013 weighing dynamic zeroing successful done for the left hand side. |
| 83 | Right hand side domestic bin | READY DYN ZERO WEIGHING | VDH9013 weighing dynamic zeroing successful done for the righthand side. |
| 84 | | SERVICE REQUIRED | The bin lift has reached its service interval date and requires maintenance. This message will start to appear just prior to the date, if the maintenance is not done within 6 months after the maintenance date the bin lift will go into "limp" mode to prevent possible damage. Contact your Terberg service partner for more details. |
| 85 | Left hand side lifter | PRESSURE SENSOR FAULT | Pressure sensor/analogue input 01.0 for measuring the oil pressure on the left hand side shows wrong information. The analogue value it supposed to send is too low or too high according to specification. The lifting chairs are lifted by a crane. There is contact with the floor. If this is not the case check the pressure sensor and cable. |
| 86 | Right hand side lifter | PRESSURE SENSOR FAULT | Pressure sensor / analogue input for measuring the oil pressure on the right hand side shows wrong information. The analogue value it supposed to send is too low or too high according to specification. The lifting chairs are lifted up by a crane. There is contact with the floor. If this is not the case check the pressure sensor and cable. |
| 87 | Left hand side domestic bin | FAULT DYN ZERO WEIGHING L/H | VDH9013 weighing dynamic zeroing fails. |
| 88 | Right hand side domestic bin | FAULT DYN ZERO WEIGHING R/H | VDH9013 weighing dynamic zeroing fails. |
| 89 | Left hand side | L VDH9013 ZERO DRIFT ERROR | VDH9013 weighing dynamic zeroing fails. |
| 90 | Left hand side | L VDH9013 ERR NO ZERO CALIB. POINT | VDH9013 weighing dynamic zeroing fails. |

| Number | Note: | Displayed text | Event description |
|--------|-------------------------------------|--|---|
| 91 | Left hand side | L VDH9013 ERR ZERO REPEAT MESURE | VDH9013 weighing dynamic zeroing fails. |
| 92 | Right hand side domestic bin | R VDH9013 ZERO DRIFT ERROR | VDH9013 weighing dynamic zeroing fails. |
| 93 | Right hand side domestic binr | R VDH9013 ERR NO ZERO CALIB. POINT | VDH9013 weighing dynamic zeroing fails. |
| 94 | Right hand side domestic bin | R VDH9013 ERR ZERO REPEAT MESURE | VDH9013 weighing dynamic zeroing fails. |
| 95 | Left hand side lifter | ADJUST DYN ZERO WEIGHING | VDH9013 weighing dynamic zeroing is active. |
| 96 | Right hand side domestic bin | ADJUST DYN ZERO WEIGHING | VDH9013 weighing dynamic zeroing is active. |
| 97 | Left hand side lifter | MOTOR CONTROLLER ERROR | For Electric lifters with CAN to CAN interface only. The left hand motor controller has detected one or more errors. |
| 98 | Right hand side lifter | MOTOR CONTROLLER ERROR | For Electric lifters with CAN to CAN interface only. The right hand motor controller has detected one or more errors. |
| 104 | | FOOTBOARD PROTECTION STOP | Pick-up arms open possible damage foot boards |
| 105 | | DIAMOND AND COMB UNLOCKED | The comb lock option is not set by use of diamond comb. |
| 124 | | CLEANOPEN COMM IDENT IS NOT READY | For bin lifts with an external identification system connected to the bin lifts Clean Open CAN connection port and the bin lift has been setup to stop when this Third party identification system is not ready (offline). The bin lift stops to prevent illegal emptying of bins without identification. Make sure this identification system is online and ready to communicate. |
| 126 | | CRANE CHUTE OPERATION ACTIVE | |
| 150 | | TMDW9020 INFORMATION | TMDW9020 Weighing system information |

| Number | Note: | Displayed text | Event description |
|--------|------------------------------|------------------------------------|-------------------------------|
| 151 | Left hand side domestic bin | TMDW9020 WEIGHING STOP LH | VDH9013 weighing stop. |
| 152 | Right hand side domestic bin | TMDW9020 WEIGHING STOP RH | VDH9013 weighing stop. |
| 153 | 4W/Trade bin | TMDW9020 WEIGHING STOP TRADE | VDH9020 weighing stop. |
| 154 | | TMDW9020 SYSTEM STOP | TMDW9020 Weighing system stop |
| 155 | Left hand side domestic bin | TMDW9020 IDENT STOP LH | VDH9013 ident stop. |
| 156 | Right hand side domestic bin | TMDW9020 IDENT STOP RH | VDH9013 ident stop. |
| 157 | 4W/Trade bin | TMDW9020 IDENT STOP TRADE | VDH9020 ident stop. |

5 Dimensions bin lift system and compactor body

5.1 Dimensions of the bin lift system

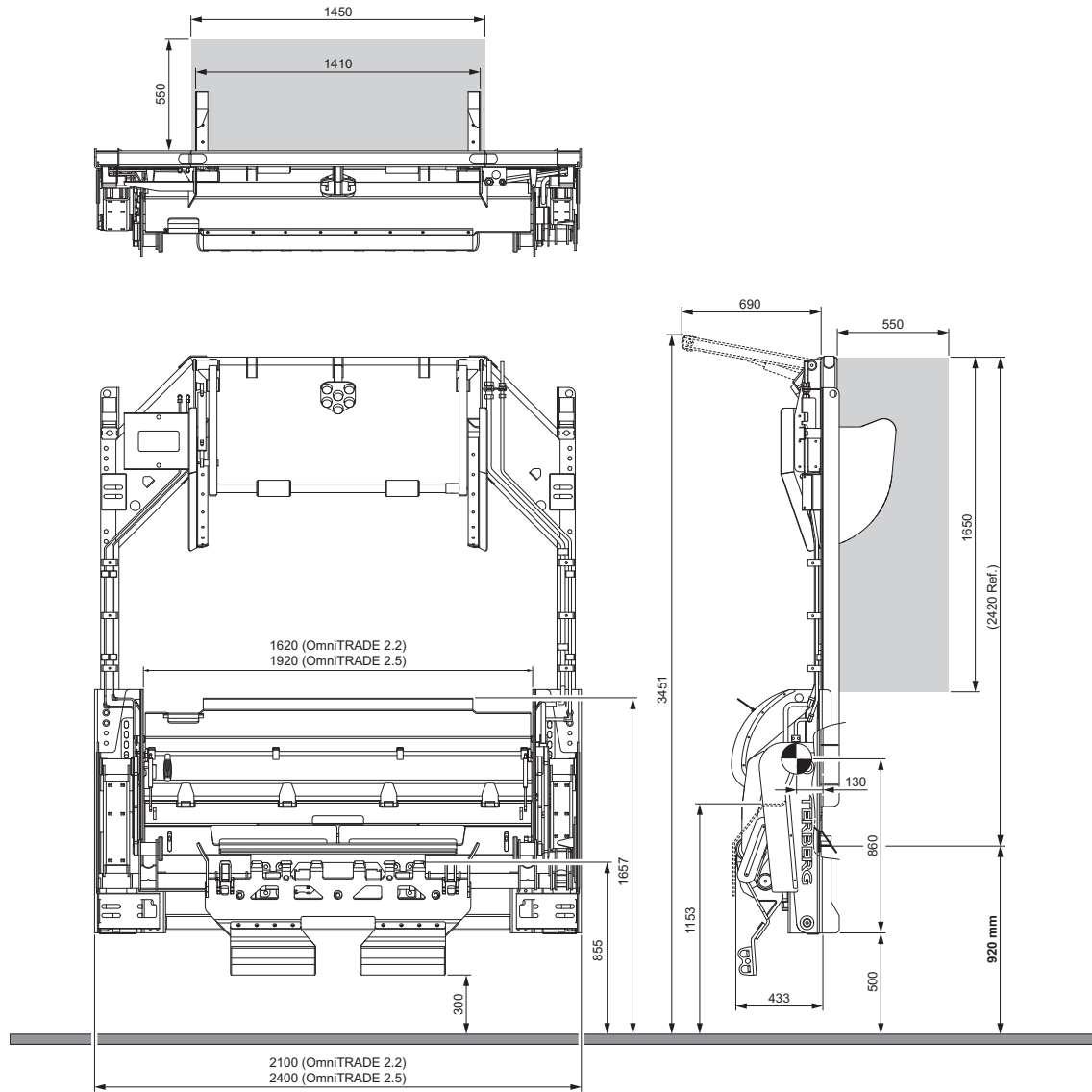

5.2 Required dimensions of the compactor body

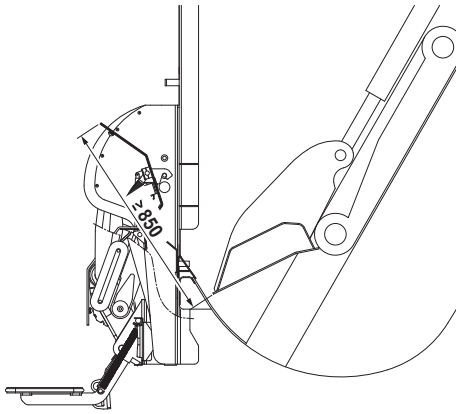

Free space from the hopper plate edge
> 850 mm.

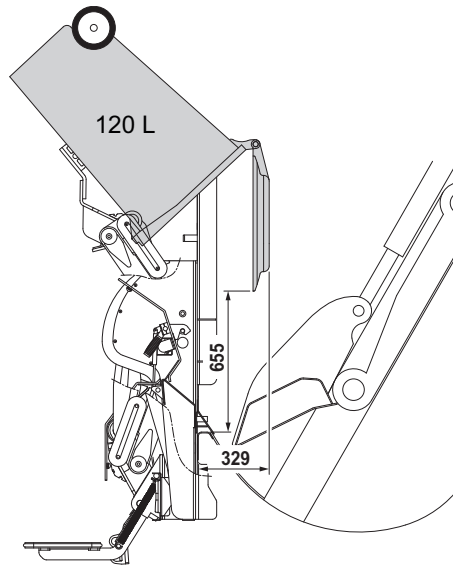

Space needed for tilted 120 litre 2-wheel bin.

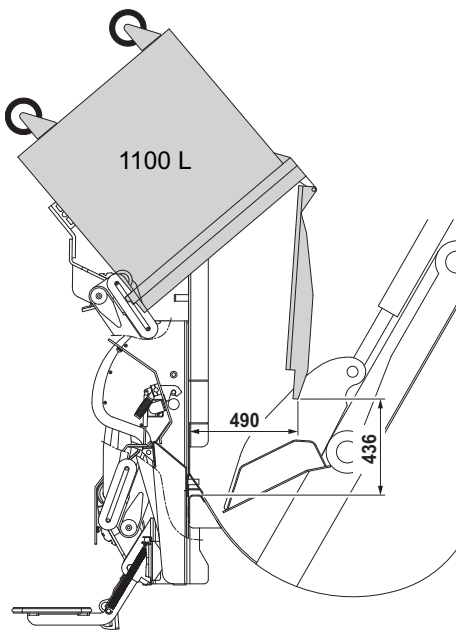

Space needed for tilted 1100 litre 4-wheel container with FLAT lid.
If there is not enough room, the interlock function must be used. This function stops the compactor and container from coming into contact with each other (anti-collision).

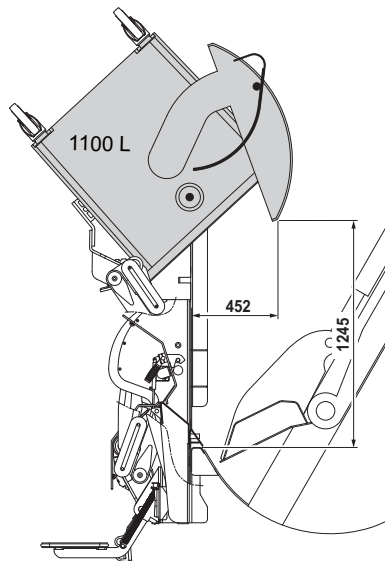

Space needed for tilted 1100 litre 4-wheel container with ROLL top.

6 Installation

6.1 Installation on the body

Required tools

- Spanners / ring spanners 10, 19 and 24 mm.
- Mobile hoist / crane with a minimum lifting capacity of 1000 kg.
- Hoist beam with chains.



CAUTION

When you mount the bin lift on the compactor, you must observe BS EN 1501-5

Safety

- Ensure that the refuse collection vehicle on which you install the bin lift, stands on a level surface.
- Remove the ignition key from the ignition switch
Keep it on your person.

Lifting

Take into account the center of gravity of the bin lift when you raise it with a fork-lift truck or hoist (see the drawing 'bin lift dimensions' in "[Dimensions bin lift system and compactor body](#)" on page 46).

- Use the following lifting points for raising the bin lift.

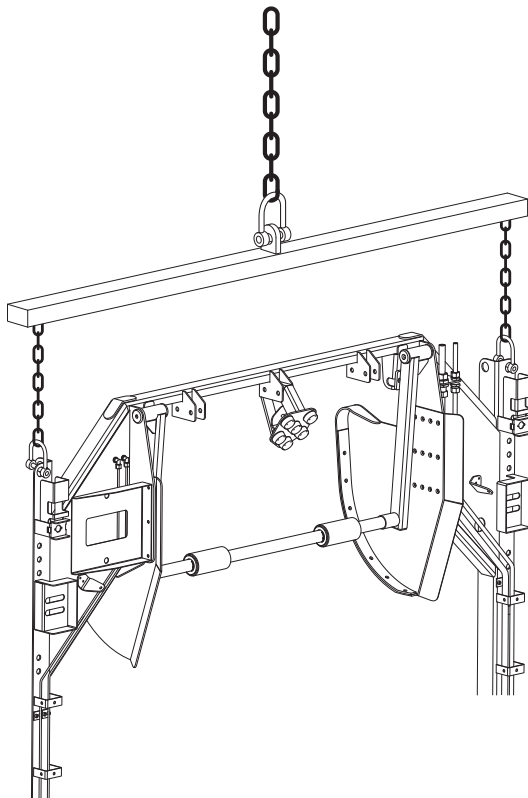

For weight information see "[Bin lift operation](#)" on page 16.

Use a mobile hoist / crane with a minimum lifting capacity of 1000 kg in combination with a hoist beam.



CAUTION

When you mount the bin lift at a height of 950 mm or more, you must mount the hopper plate at the highest position.

Installation on the body using Terberg Machines mounting/interface frame

- Apply a pattern of holes to the rear of the refuse collection vehicle as shown in the drawing below.
- Install a refuse guide plate at an angle of at least 45° (see drawing). This plate guides the refuse into the hopper.
- Mount the bin lift onto a hoist beam and lift it to the mounting height.



NOTE

Before you lift, check that the pick-up comb is in the lower position.

Mounting height for loaded refuse collection vehicle

Minimum: 900 mm

Maximum: 950 mm

Terberg Machines B.V. advises 920 mm.

Rear of refuse collection vehicle

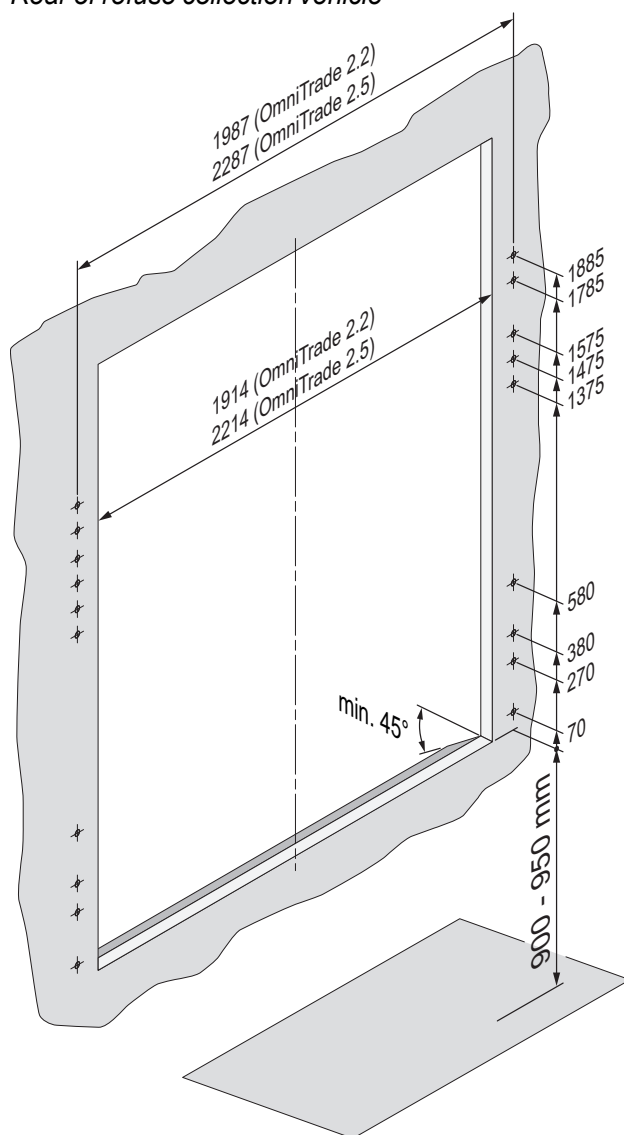

Secure the bin lift using M16 bolts (class 8.8), lock nuts and washers (DIN 6340) to the mounting frame of the refuse collection vehicle (tightening torque 200 Nm).

6.2 Installation of the body (without mounting frame)

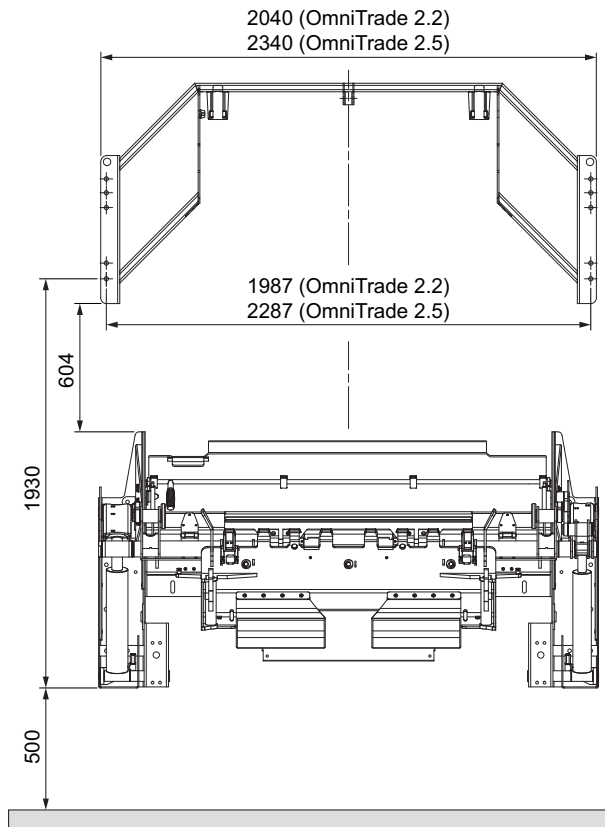

- Fit mounting plates onto the rear of the refuse collection vehicle as shown in the drawing, right.
- The mounting plates must have mounting holes at the positions shown.

Mounting height for loaded refuse collection vehicle:

Minimum: 900 mm

Maximum: 950 mm

Terberg Machines B.V. advises 920 mm.

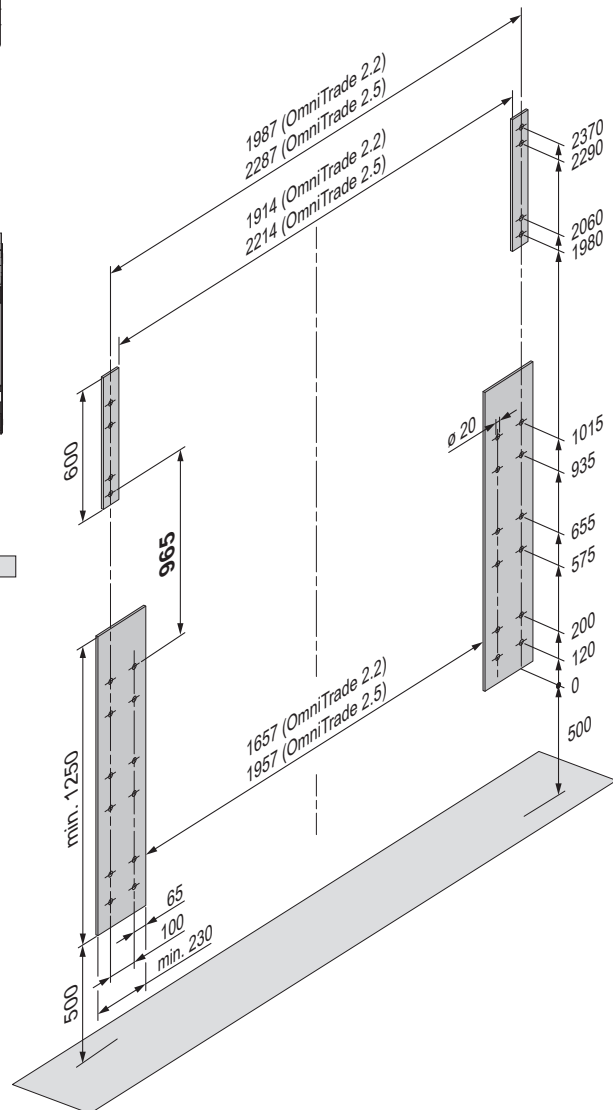

CAUTION

When you mount the bin lift at 950 mm or higher, you must mount the hopper plate at the highest position

6.3 Footboards: installation advice

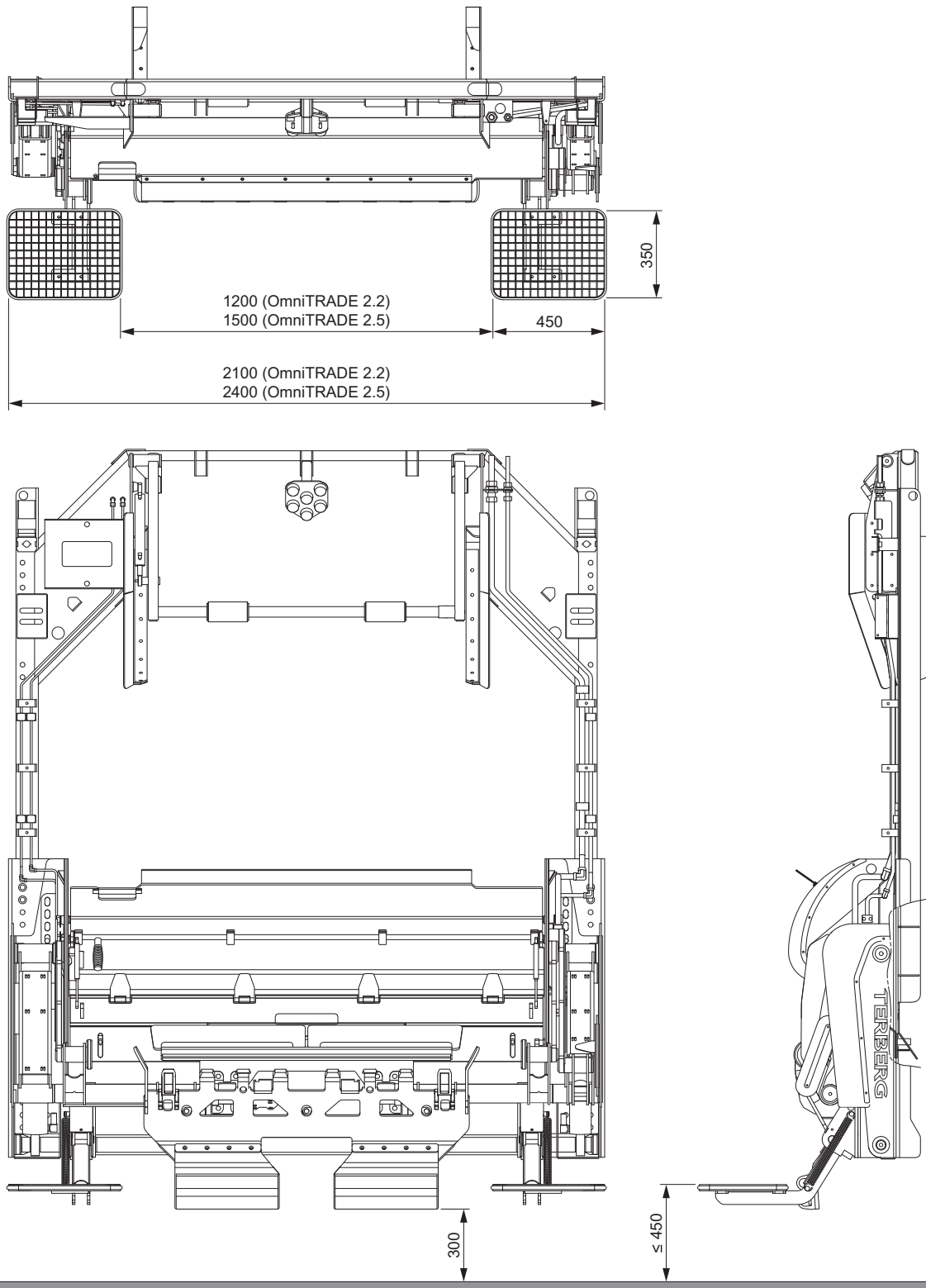

CAUTION

Connect the sensors of the foot boards according to the recommendation of the body manufacturer.

6.4 Hydraulic connection

At the top R/H side are two capped connections. Connect these to the compactor body of the refuse collection vehicle. For more information, see also "[Hydraulics](#)" on page 59).

- The R/H coupling 15mm is for the supply (P).
- The L/H coupling 22mm is for the return (T).
- Make sure the oil supply never exceeds 60 litres/min. If the oil supply is higher than it, get in touch with the body supplier.
- When working on the hydraulic system, always remember that it is filled with hydraulic fluid under pressure.
- Ensure there is enough clean oil in the hydraulic system.
- The oil filter in the refuse handling body should have a filter rating of 25 microns.

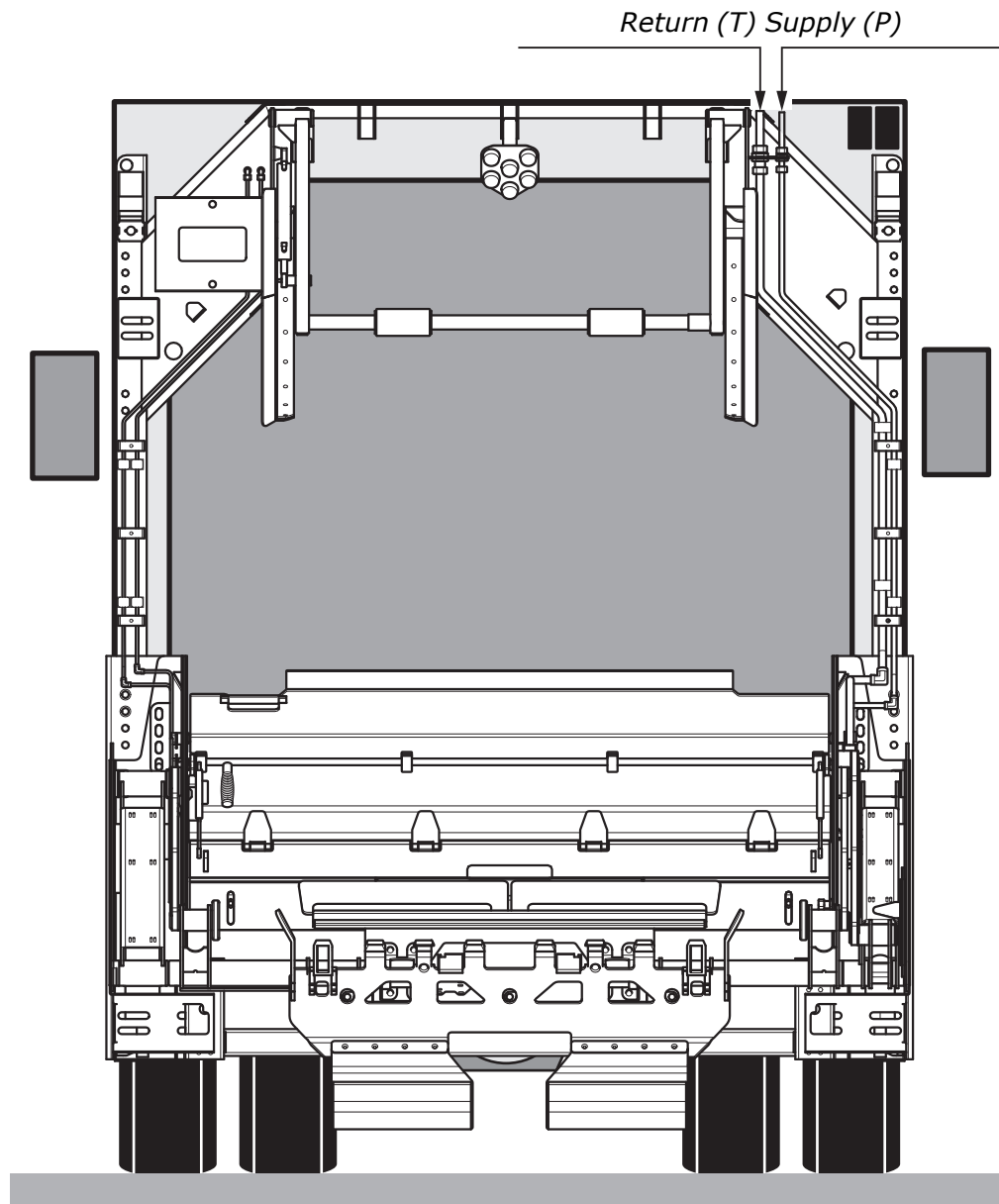

**CAUTION**

Never use the bin lift with an oil supply of more than 60 litres/min.

**CAUTION**

Always use equipment that avoids contact with the skin and eyes.

**CAUTION**

Use absorbents to avoid pollution of the environment.

**NOTE**

Read the operating instructions before you use the bin lift.

6.5 Electrical connection

The bin lift is connected to the body in accordance with the EN 1501-5 standard.



CAUTION

Make sure that the work area of the compactor mechanism is sufficient protected.



CAUTION

The following work may only be carried out by qualified personnel.

- Check the following before connecting
 - Start the vehicle
 - Start the compactor system.
 - Press the Start button of the compactor.
 - The compactor may now operate as a hold-to-run system - as soon as the Start button of the compactor system is released, the compactor must stop.
 - Check to ensure that the emergency stop switches of the compactor body function correctly and that the emergency stop buzzer in the cabin works.
 - Reset the emergency stop switches and check again that the compactor works as a hold-to-run system.
- Remove the 16-pin plug from the 16-pin socket.
- Put the plug of the compactor body into the socket of the bin lift.
- Put the plug from the bin lift into the socket on the compactor body.

Electrical plugs and sockets

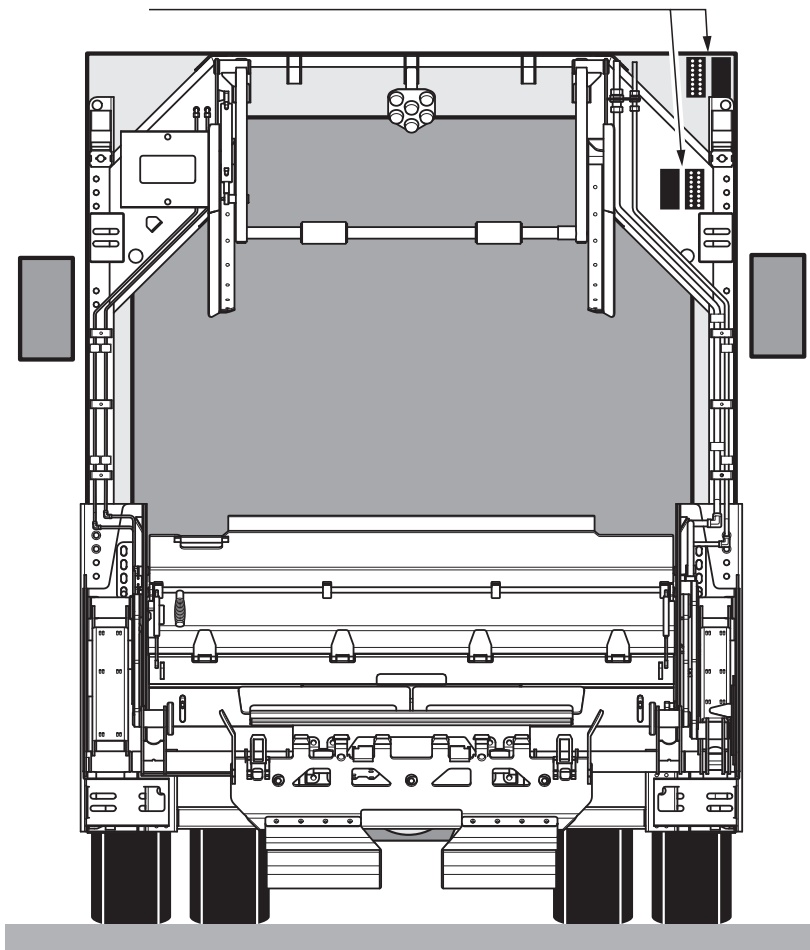

Explanation of pin assignment for interface cable

16-pin plug of the bin lift

| Pin number | Signal type | Description | Observation |
|------------|-------------|---|---|
| 1 | Supply | Power supply in | +24 V, direct from chassis, maximum 5 A |
| 2 | Supply | Power supply in | +24 V, direct from chassis, maximum 5 A (linked with Pin 1) |
| 3 | Gnd | Ground | Mass of chassis, maximum 3 A |
| 4 | Gnd | Ground | Mass of chassis, maximum 3 A (linked with Pin 3) |
| 5 | Input | Reverse gear engaged +24V | |
| 6 | Output | Chairs low position, not in travel position +24 V | |
| 7 | Bus | CleAN open* CAN (L) | |
| 8 | Input | Emergency stop circuit 1 | Loop 1, output from RCV to bin lift system, maximum 300 mA and 50 V |
| 9 | Output | Emergency stop circuit 1 | Loop 1, output from bin lift system to RCV maximum 300 mA and 50 V |
| 10 | Input | Emergency stop circuit 2 | Loop 2, output from RCV to bin lift system, maximum 300 mA and 50 V |
| 11 | Output | Emergency stop circuit 2 | Loop 2, output from bin lift system to RCV, maximum 300 mA and 50 V |
| 12 | Output | Container pulse count (one pulse per container, no matter if 2- or 4-wheeled) | +24 V, 300 ms 1 sec. maximum |
| 13 | Input | "RCV" ready | |
| 14 | Output | Hydraulic supply request and engine speed request (+24 V) | |
| 15 | Bus | CleAN open CAN (H) | |
| 16 | Output | Start compaction cycle | +24 V, 300 ms 1 sec. maximum |

* CleAN open is a CAN data protocol for refuse collection vehicles.

It makes data communication possible between the various components (bin lift, identification system, weighing system, and the like) of the refuse collection vehicle.

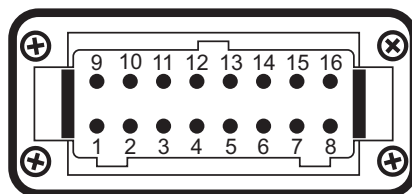
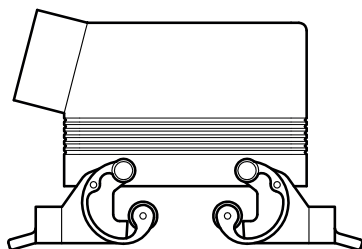

| Pin number | Signal type | Signal description | Observation |
|------------|-------------|---|---|
| 1 | Input | RCV in neutral gear = + 24V | 16 to 34V |
| 2 | | Not connected | Information that no bin lift is installed |
| 3 | Output | Position of packer plate safe from foot board level | |
| 4 | Output | Position of packer plate safe from foot board level | |
| 5 | Input | Footboards OCCUPIED, 0 volts | |
| 6 | Output | Clash between bin lift and packer plate (information to RCV that the container is within reach of the packer plate) | +24V = The packer plate stops. As soon as the container is out of reach of the packer plate, an extra start signal for the compaction cycle is given. |
| 7 | Bus | CleAN open CAN (L) | |
| 8 | | Not connected | |
| 9 | | Not connected | |
| 10 | | Not connected | |
| 11 | | Not connected | |
| 12 | Input | Emergency stop check signal: normal "safe"state = +24V | Maximum 5A |
| 13 | Output | Position of packer plate safe from ground level (+24V) | |
| 14 | Input | Clash between packer plate and bin lift (information to bin lift that packer plate is within reach of container) | +24V = bin lift stops in horizontal positions outside the reach of the packer plate. |
| 15 | Bus | CleAN open CAN (H) | |
| 16 | Output | Position of packer plate safe from ground level (+24V) | |

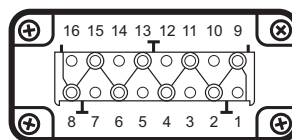
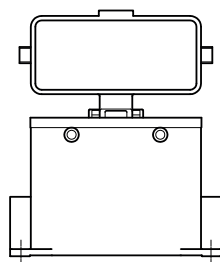

6.6 Installation push button control station

Your Omnitrade bin lift system comes with a loose push button box and a mounting plate to attach it to the RVC. Place the button box as close to the bin lift system as possible. **Do not** attach it as in the picture below. This will confuse the operators of the bin lift and result in errors and possibly accidents.



Procedure



1. Attach the mounting plate of the push button box to the RVC.
2. Connect the power plug of the push button box to the electrical circuit of the RVC

7 Hydraulics

7.1 Hydraulic connections and components

The OMNITRADE (e) bin lift system uses the hydraulic facilities of the compaction body.

Ensure that there is enough clean oil in the hydraulic system.

For topping up, the viscosity of the hydraulic oil as well as the oil change intervals, see the user manual of the body manufacturer.



CAUTION

Terberg Machines cannot be held liable for damage that occurs to the bin lift system as a consequence of using dirty oil.



CAUTION

All forms of warranty laps if it is found that the set pressures and flow rates have been changed.

For trouble-free operation of the bin lift system, the vehicle's hydraulic system should have a flow rate of between 40 and 60 liters per minute.

The minimum pressure must be 190 bar and the maximum 250 bar. Maximum return pressure is 2 bar.

When the system is in operation, check that there are no leaks.

Fix any leaks by turning the leaking couplings slightly.

It is not permitted to change pressure settings and flow velocities. These are set by the manufacturer.

The fitted seals may not be broken.



CAUTION

Always use personal protection equipment to avoid contact with the skin and eyes.



CAUTION

Use absorbents to avoid polluting the environment.

Optionally, the bin lift can be prepared for a vehicle with a closed hydraulic system with an adjustable load sense pump.

Operation

The optional 'Load sense' valve block on the bin lift will request the pump flow, required by the controllable pump, and send this flow to the bin lift.

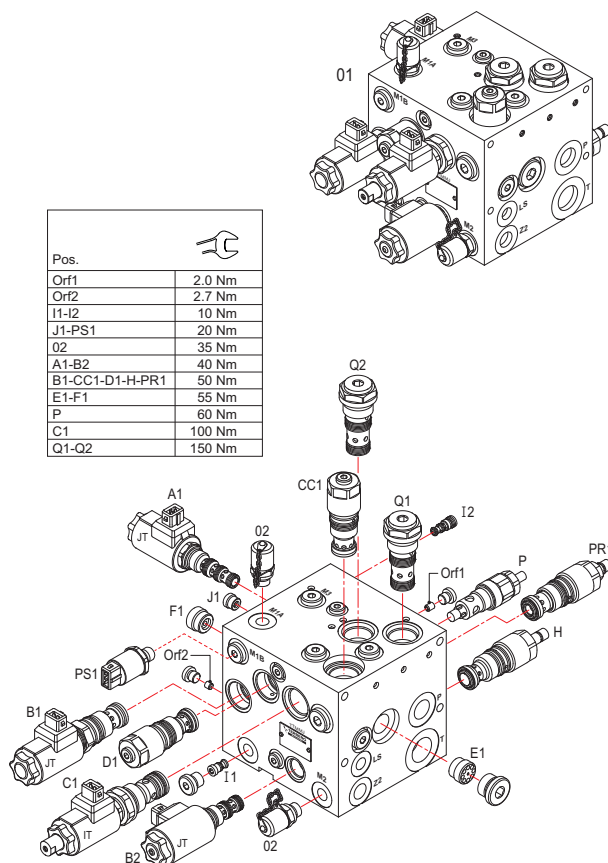

| Number | Part number | Description |
|---------|-------------|-----------------------------|
| 01 | 417731 | Hydraulics block |
| A1 | 417763 | Valve A 4/2 |
| B1 | 417764 | Valve B 2/2 |
| B2 | 37902 | Valve 4/2 |
| C1 | 417765 | Proportional Throttle |
| CC1 | 417766 | Inline pressure-compensator |
| D1 | 417767 | Bypass pressure-compensator |
| E1 - F1 | 417768 | Check Valve |
| H | 37906 | Pressure relief valve |
| I1 | 417770 | Shuttle Valve |
| I2 | 417771 | Shuttle Valve |
| J | 37911 | Check valve |
| P | 417772 | Pressure relief valve |
| PR1 | 417773 | Pressure reducing valve |
| Q1 | 417774 | 2/2 logic valve |
| Q2 | 417775 | 2/2 logic valve |
| Orf1 | 37927 | Flow limiter M6/0.35mm |
| Orf2 | 417776 | Flow limiter M6/1,2mm |
| JT | 37912 | Coil 24 Volt |
| IT | 37913 | Coil 24 Volt |
| PS1 | 10431 | Pressure sensor |

| Number | Part number | Description |
|--------|-------------|-----------------|
| 02 | 22645 | Test nipple M16 |

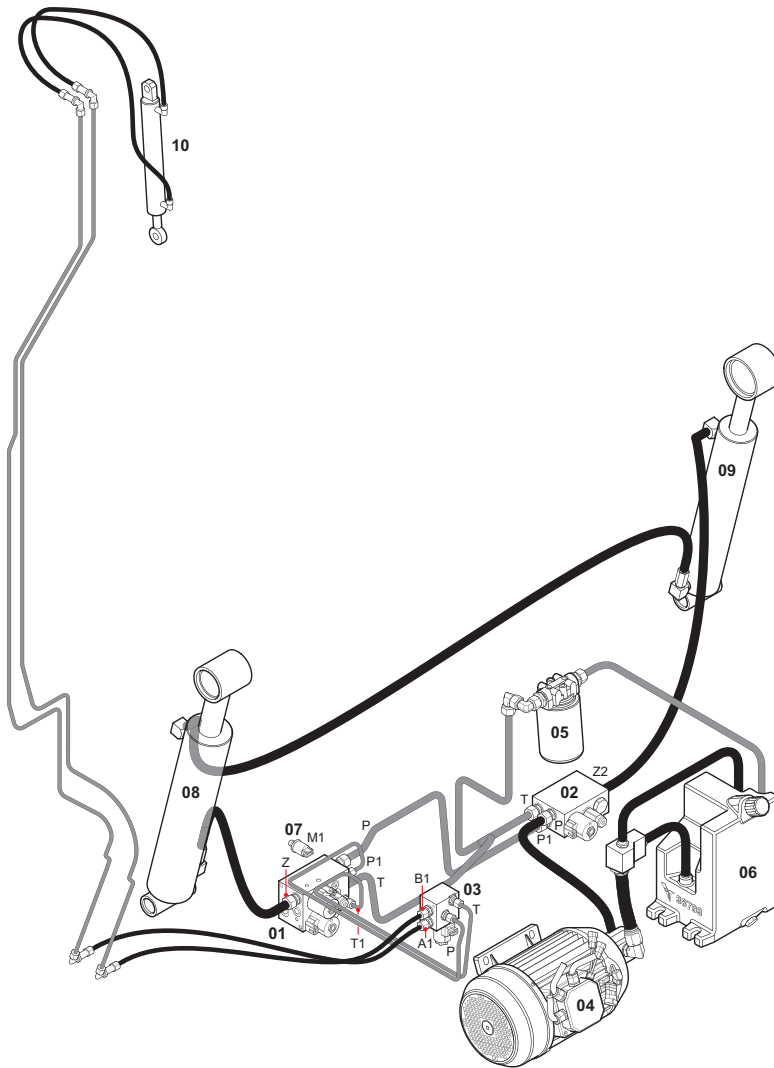

- 01** Valve block(26930)
- 02** Valve block (37561)
- 03** Valve Catcherbar (417726)
- 04** Pump unit 4.5 Kw (417758)
- 05** Filter body with oil filter (18969 / 18968)
- 06** Hydraulic tank (38793)
- 07** Pressure sensor (10431)
- 08** Cylinder Master ((10431)
- 09** Cylinder Slave (38825)
- 10** Cylindercatcherbar (14177)

8 Electrical

8.1 Electrical connections and components (P&P) (UK version)

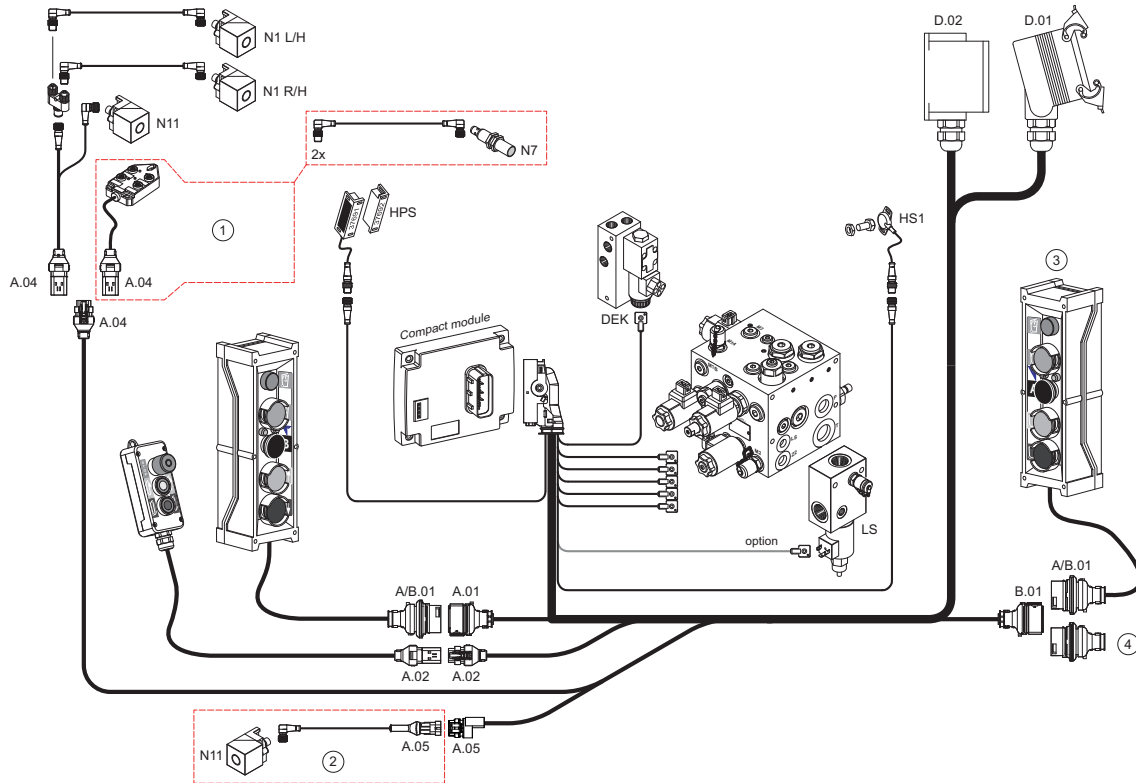

| | |
|--|--|
| D.01 16-pin plug of the bin lift | 1. If pick-up arms are installed , this splitter box is used. The two N1 sensors and the two N7 pick up arm sensors are connected here. The N11 sensor then goes to connection A.05 |
| D.02 16-pin plug socket of the bin lift | |
| DEK Catcherbar valve | 2. This only happens if pick-up arms are installed. See point 1. |
| HPS Hopper plate switch | |
| HSI Position sensor | 3. A second control station is an option |
| LS Load sense valve | |
| N1 L/H Start sensor L/H | 4. Blind plug |
| N1 R/H Start sensor R/H | |
| N11 Sensor 4-wheel recognition | |

8.2 Electrical diagram

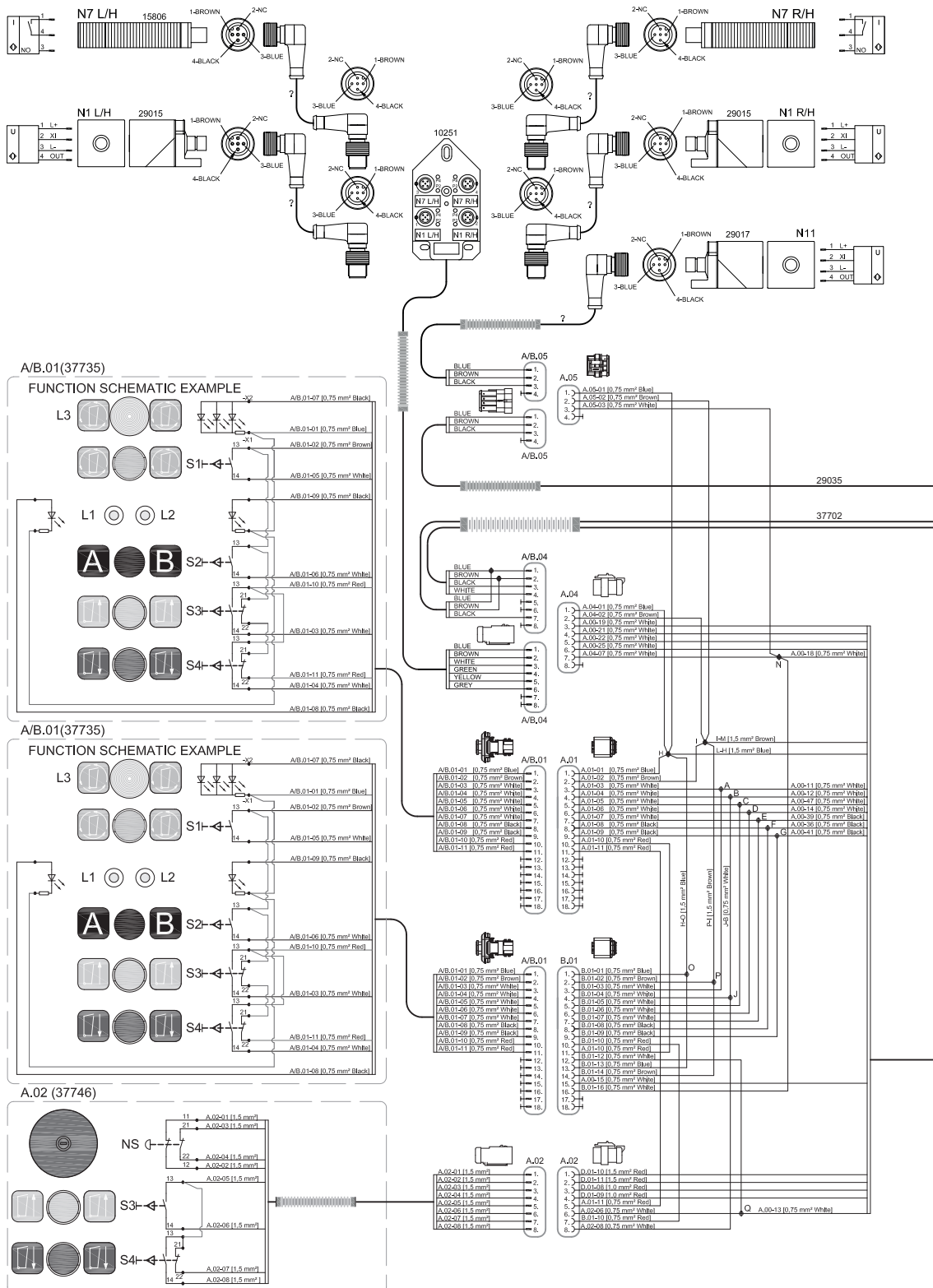

9 Decommissioning (disposal)

Follow the procedure below:

1. Dismantle the bin lift from the refuse collection vehicle.
2. Place it horizontally.
Bear in mind the center of gravity of the bin lift when you lift it.
3. Use a hoisting gantry with a minimum lifting capacity of 1000 kg and a hoist beam or
or
use a double chain sling
4. Use the lifting points present for hoisting the bin lift.

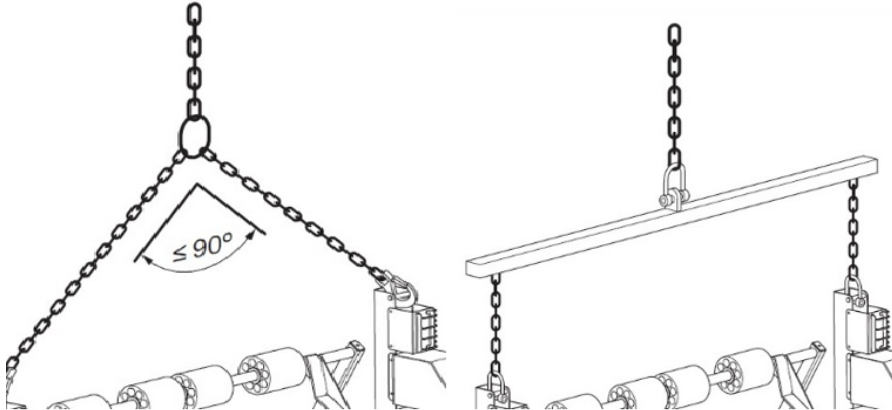

5. Dismount all springs that are mounted with pretensioning.
6. Drain off the hydraulic oil.
7. Dispose of the various materials in accordance with the current local (legal) provisions.



CAUTION

Use collecting trays / absorbents to avoid polluting the environment



WARNING

Always use personal protection equipment to avoid contact with the skin and eyes

9 Terberg Connect

Terberg Connect gives the fleet manager a detailed overview of his fleet of RCVs. It can provide him with detailed information per RCV on the body, bin lifter, chassis and weighing / RFID system. It is possible to edit certain settings to ensure continuity when switching between refuse types or areas.

Functionality

After selecting a RCV it is possible to see the location of the vehicle and view the statistics on daily and total 2- and 4-wheel counters and operating times in the Vehicle details dashboard. The bin lifter overview shows the real time status of settings, sensors, inputs and outputs as well as the diagnostic display. On body page the real time sensor data, settings, the hydraulic data and the status of valves are shown. Weighing /RFID information is presented in great detail: location, net, gross, tare weights. and possible error codes are available for every emptying. Export of these records on date to Excel or CSV is possible. To receive a daily drop file with weighing results an email address can be entered on the reporting page. The weighing and/or RFID can remotely be switched on or off in the settings menu.

Maintenance

All events, like info messages, alarms and / or error messages, are stored. Accessible in a historical list. In this way fleet performance can be optimized and maintenance costs are reduced.

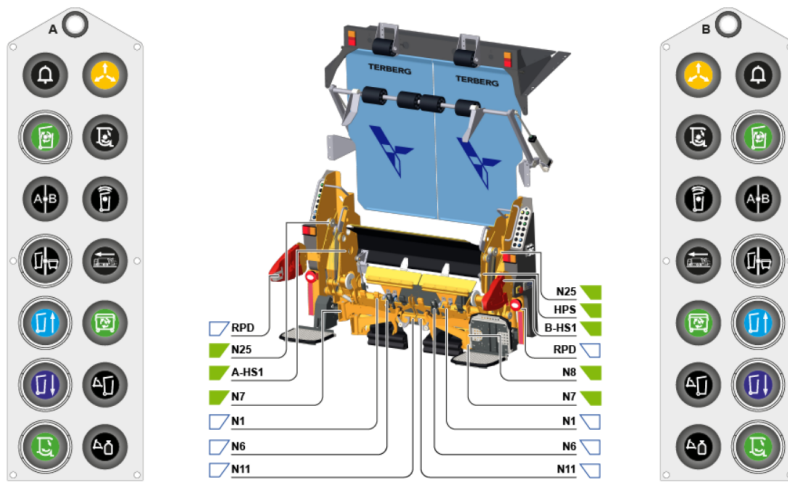

Functioning bin lift, showing sensors and button boxes.

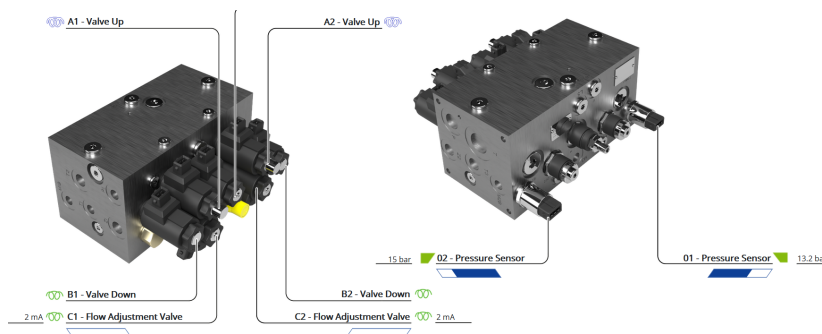

Hydraulics of a bin lift

10 Options

Pickup arms

To collect bigger containers the bin lift system can be equipped with DIN arms on either side of the bin lift system to lift and empty the container.

Footboards and handles

To offer extra protection to the bin lift operators, the bin lift can be equipped with foot boards and handles on either side of the bin lift.

Weighing system

Description of the TMDW system

TMDW stands for Terberg Machines Dynamic Weighing. There are three different TMDW setups:

- RFID Only,
sends tag number
- Weighing Only
sends weighing related data like bin or container, L/H or R/H, time, and net, gross and tarre.
- Weighing & RFID.
sends weighing related data like bin or container, L/H or R/H, time, and net, gross and tarre weight, and tag number.

The TMDW systems are fully automated for identifying waste bins fitted with a Low Frequency transponder and/or for Dynamic weighing, meaning weighing during movement. These systems can only be integrated into bin lift systems.

The Weighing and RFID system conform to the MID guidelines, OIML R51 class Y(b) and is approved under certificate No. T11355. The final weighing result of a full lift cycle is shown on the display of the Diagnostic System on the bin lift.

Weighing & RFID Operation

The weighing cells on the TMDW system record the emptied container weight of the containers during the lifting process. This is individually done on the L/H side (weighing cell W1) and the R/H side (weighing cell W2). The weight of 4- wheel containers is recorded with coupled chairs. The measurements from the 2 weighing cells (W1 + W2) are added to create W3 results.

The net refuse weight is calculated by subtracting the lowered weight from the container from the lifted container.

RFID Operation

The two installed RFID antenna (1, 2) on the bin lift identify the transponders (3) via radio frequency. They are fitted in the comb edge of the containers. This automated process is completed during the lifting cycle on the L/H side (system 1) and the R/H side (system 2).

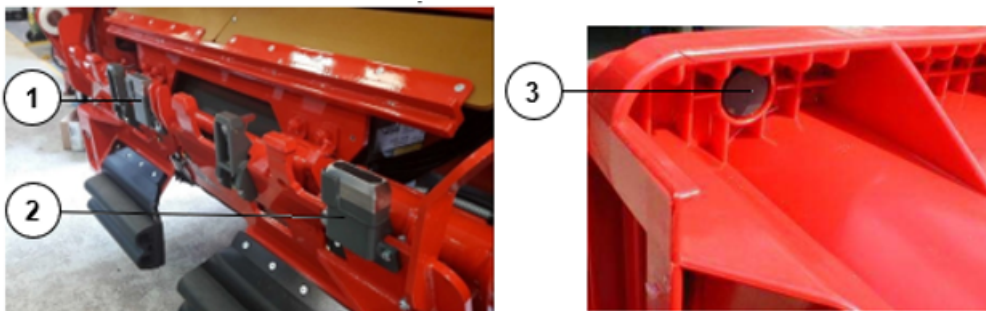

4-Wheel containers will only be identified by the R/H side chair (system 3) when the chairs are coupled together.

Collection data

The collection data from the TMDW system are wirelessly transferred. The individual bin lift records of the RFID setup contain the GPS location of the collection point.

The records are:

- offered within 24 hours to a customer email address (Daily File Drop)
- or viewed within seconds via the Terberg Connect system.
- alternatively the collection data is transferred to a Third party On Board Computer or modem via a TMOpen data interface.

The RFID system works with a Stop/Go list. For this option you need to have TM Open Interface for transferring the collection data files. The Stop list holds bins and containers that are missing or should not be counted.

TMDW technical specifications

| Weighing configuration | | Left and or right weighing (2 wheel bins) | Combined weighing (4 wheel bins) | |
|-------------------------------------|-------------------|--|----------------------------------|----------------|
| Destined to be used as | | Catchweigher | | |
| Accuracy class | | Y(b) | | |
| Maximum capacity | | 160kg | 400kg | 800kg |
| Minimum capacity | | Minimum $\geq 5 e$ | | |
| Verification scale interval | | $e \geq 0.5kg$ | $e \geq 2.0kg$ | $e \geq 5.0kg$ |
| Weighing range | | Single interval | | |
| Maximum number of scale intervals | | $n \leq 320$ | $n \leq 200$ | $n \leq 160$ |
| Tare | | $T \leq 50kg$ | $T \leq 150kg$ | $T \leq 150kg$ |
| Electromagnetic Environmental Class | | E3 | | |
| Mechanical Environmental Class | | M3 Instrument can be incorporated into vehicles | | |
| Climatic environment | Temperature Range | $-10^{\circ}C / +40^{\circ}C$ | | |
| | Humidity | Non-Condensing | | |
| | Intended Location | Open and Closed | | |
| Power supply voltage | | 24V DC vehicle battery | | |
| RFID specification | | Low Frequency - Multifrequency 125KHz - 134KHz Multiprotocol FDX-B / HDX | | |
| RFID antenna | | Stainless Steel + Epoxy (Aircoil) or ABS + Epoxy (Aircoil / Ferrite) | | |

Transfer collection Data

The collection data created by the TMDW weighing & RFID system can be transferred to you in a number of ways, depending on the choice you made.

The possibilities are:

- **Daily File Drop**

This is the sending to a server of the collection records via the Connect modem. Subsequently these files are on a daily basis sent to a dedicated email address. They contain all weighing records of the previous day. You can import this (*.csv) file into your back office software or open it with MS Excel. You can add, delete or edit your e-mail address for a specific RVC in Terberg Connect.

Another possibility is to place the collection records on a FTP server instead of sending them by email.

- **TM Connect web page**

The collection data are shown on the web page. You export the historical collections from a specific date into an Excel document.

- **Remote Database Connection**

In this option your back office software interfaces with the server for weighing and vehicle diagnostics data.

- **TM Open Interface**

In this option collection records are sent over a serial interface to a 3rd Party On Board Computer (OBC) or modem by using a RS232 connection.

A Bluetooth device can be fitted to the end of TMOpen cable if the 3rd party device does not have a conventional serial port such as an Android Notepad or Phone.

- **Combine TMDW Weighing and RFID system with an AMCS Routeman On Board Computer System.**

In this case the TMDW system outputs the collection data in an agreed format acceptable by AMCS. The Routeman OBC forwards the TMDW data to the AMCS Server.

Send Stop list using TM Open Interface

On the Stop list, RFID transponder numbers are loaded. They represent containers that are missing, or containers that should not be collected on a specific round. The TMDW RFID systems and TMDW Weighing & RFID systems work with Stop/Go lists for controlling containers fitted with RFID transponders.

You transfer the Stop/Go list through the 3rd Party OBC to the TMDW system using the TMOpen interface. Also possible is that the Stop/Go list is picked up by the server from your FTP site and sent directly to the TMDW Connect module on the vehicle.