

Specifications

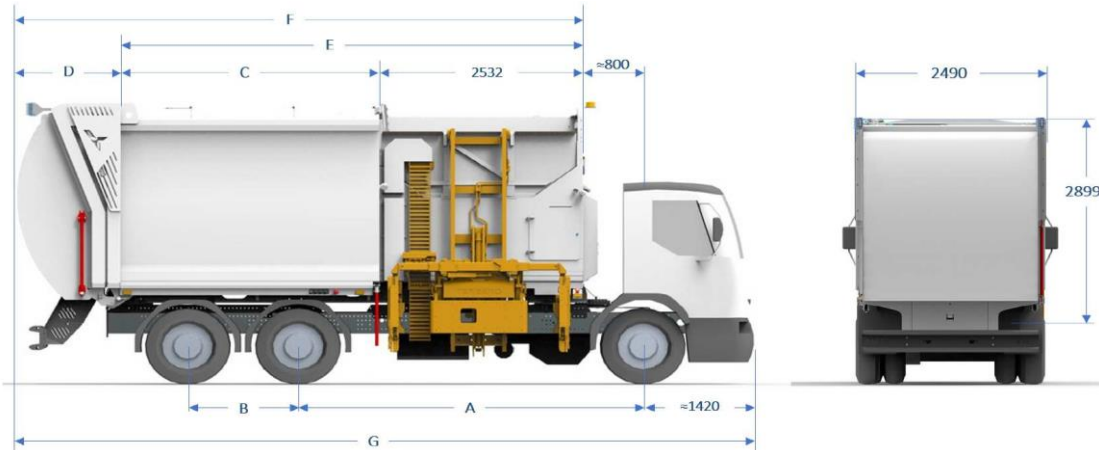

MODEL		SLM-15	SLM-17	SLM-20	SLM-22	SLM-23	SLM-25	SLM-26	SLM-28
WEIGHTS AND DIMENSIONS									
GVW chassis (t) (1)		18	18	18	26	26	26	26/32	26/32
SLM useful capacity (m ³)		15,1	17,0	19,7	21,6	22,2	24,1	24,8	26,7
Hopper useful capacity (m ³)		6 (1,7 + 4,3)							
Total Weight including lifter (Kg)		8275	8375	8600	8700	8800	8900	9000	9100
Recommended Wheelbase: 1- 2 (mm)	A	4200-4300	4200-4300	3900-4100	3900-4100	4200-4500	4200-4500	4400-4500	4400-4500
Recommended Wheelbase: 2- 3 (mm))	B	-	-	1350-1400	1350-1400	1350-1400	1350-1400	1350-1400	1350-1400
Body length (mm)	C	2050	2050	2900	2900	3400	3400	3900	3900
Rear door length (mm)	D	735	1120	735	1120	735	1120	735	1120
Body + hopper and compaction system length (mm)	E	4590	4590	5440	5440	5940	5940	6440	6440
Total Length SLM (mm)	F	5325	5710	6175	6560	6675	7060	7175	7560
Total Length RCV (mm) *	G	7545	7930	8395	8780	8895	9280	9395	9780
TECHNICAL SPECIFICATIONS									
Working system		Hydraulic / Pneumatic /Electric							
Maximum compaction ratio		7:1							
Container lifting cycle time (2400 Lt container @ min/max distance. (s)		29/32							
Max. Lifting capacity (Kg)		1500 kg in "Heavy duty" mode 1200 kg in "Automatic" mode							
Absorption speed (m ³ /min)		9,27							
Compaction cycle time (s)		11							
Body unloading system		Mobile ejector plate							
Unloading cycle time (s)		90							
Centring error (mm)		230							
Oblique offset of the container (mm)		294							
Minimum/maximum coupling (mm)		820/2700							
Tipping angle of container in hopper (°)		60							
Tilting angle in relation to the ground (°)		7							
Coupling offset (mm)		± 100							
Leachate tank volume (lts)		257	328	257	328	257	328	257	328

* Overall length will vary depending on chassis front overhang and final mounting distance.



Body and rear door

- Constructed from high tensile steel one piece rolled side sheets and braced by front and rear hoops, with pressed integral channels and 'keel' type floor.
- Two leachate tanks: one at the rear door and the other in the body with a total of 328 l / 257 l depending on the model/ capacity.
- No greasing points on the compaction body.
- Reduced overhang allowing a substantial improvement in maneuverability.
- State-of-the-art underride bar approved in accordance with ECE 58-03 regulations.
- Sides in 4mm STREX70.
- Floor in 3 sections across width: 4-6mm S355 EN10025.
- Rear Hoop: 6mm S355 EN10025.
- Barrier Rails: 4mm STREX70.
- Rear door: 4mm STREX70.
- Rear door sides: 4mm STREX70.
- Rear door frame: 4mm S355 EN10025.

Hopper and compaction system

- Hopper with a volume of 4.3m³.
- Compaction chamber with a volume of 1.7m³.
- Compaction cycle time 11s.
- Compaction force up to 36210 kg.
- Use of high elastic limit steels.
- Compaction system formed by two cylinders arranged in a cross.
- Protective plate located in the front part of the body for driver safety.
- Programmable automatic compaction cycles based on the lifting cycles carried out.
- Integrated "Pack on the Move" system, to continue compacting the waste while the vehicle is running.

Refuse Ejection Plate

- Ejection plate face is manufactured from high tensile abrasion resistant steel, forming a smooth and unobstructed discharge surface.
- Self-lubricating bearings guide the ejection plate along rails within the body.
- Ejector plate activated by a single double-acting telescopic cylinder.

Electrical System

- Fully integrated CANBus system logic (CANopen) with external diagnostic connector.
- 12" display unit in cab for body controls and diagnostics.
- Valve panel and electronic system cabinet accessible through a soundproofed hinged door with sound-absorbing material, provided with a lock, opening sensor and properly lit by means of an LED bar.
- Number and colour coded wiring for easy identification, maintenance and fault finding.

Hydraulic System

- Double hydraulic vane pump with a flow rate of 130 litres/minute at 1000 rpm.
- 200 l oil tank.
- 10 microns return filter.
- Rear door lift cylinders located on the side of the bodywork.
- Centralized hydraulic system in a waterproof side cabinet with easy access for diagnosis and maintenance.

Lifter

- TERBERG automatic lifting unit located on the side of the bodywork, suitable for lifting side-loading containers from 1,700 to 3,200 liters according to Standard EN 12754.
- Lifting capacity of 1,200 kg in standard mode and 1,500 kg in "Heavy Duty" mode.
- With mechanical lock when it is in the rest or driving zone to avoid gauge outflows during displacements.
- Centralized lubrication. Allowing the entire bodywork to be greased from a single point.

Safety

- CE Approved. Safe by design. EN 1501-2.
- Two-plate design, automatic body/rear door locks and clean discharge remove the need to approach moving parts.
- Interlocks prevent the mechanism from working unless the rear door is fully lowered.
- Rear door lift rams are fitted with integral pilot operated load holding valves so that even if a hose fails, or is removed, the rear door cannot descend unless positively powered downwards.

- Indicator icons show the driver when the mechanism is in operation, and when the rear door is out of its locks.
- In cab discharge controls as standard, with external rear door lower controls for optimized safety.
- Interlocked access door for safe maintenance operations.
- Proportional joystick with capacitive sensing technology allowing the driver to have full control of all movements at any speed. Real-time detection of the operator's hand around the joystick minimizing the risk of accidental movements of the machine. Includes console with armrests.
- Automatic rescue system that in case of emergency returns the lift to the initial transport position.
- Vehicle stabilizer by hydraulic cylinder attacking the front axle leaf spring.

Options

- 700-1100L container adapter.
- Upper hopper closing
- Hopper pusher.
- Weighing systems.
- 360° camera system.
- E-PTO.
- Further standard options please contact a ROS ROCA sales representative.

This document and the information or advice given to the customer is merely for guidance and does not constitute any contractual obligation. Nor can any obligation, guarantees or responsibility be taken from it on the part of the company.

All specifications are subject to manufacturers tolerances. An allowance of +/- 2% should be made for all weights.