



OMNIDEL 50/50

LOW-LEVEL AUTOMATIC SPLIT BINLIFT

The OmniDEL 50/50 is the latest front line fully automatic split bin lift from Terberg. Featuring all of the proven features of the current OmniDEL split binlift range, but each chair is totally separated from it's neighbour making it the ideal choice for 50/50 split RCV bodies;

REASONS TO CHOOSE THE OMNIDEL 50/50

- The **OmniDEL 50/50** weighs in from as little as 860kg total for the two lifts.
- The **OmniDEL 50/50** is perfect for two wheeled containers from 80 litres all the way to 360 litres, providing you with a versatile and flexible domestic container collection solution.
- The one-of-a-kind geometry of the **OmniDEL 50/50** guarantees that the operator does not need to take a step backwards during collection cycle, and it has a remarkable discharge angle of 50°.
- A single point greasing system is integrated in the standard equipment which contributes to shorter maintenance intervals.
- as standard, **OmniDEL 50/50** is supplied with an Automatic Shaker ensuring maximum operational efficiency and can be set to shake every bin either once or twice.

SMART SOLUTIONS

- The **OmniDEL 50/50** has a unique ultrasonic anti spilling system. This system detects any material which might still be left in the bin, automatically shakes the load one time so that all remaining material is collected, and places the container back on the ground.
- The Rear Protective Device comes as standard and complies to safety norm EN 1501.5. This is active during automatic loading of the 2-wheeled containers.
- Shock and water resistant IP69K automotive parts, low-maintenance bearings, contactless sensors and switch elements offer perfect protection against the often heavy daily working conditions.
- The **OmniDEL 50/50** is designed in such a way that it lifts the container with low speed at first, and speeds up afterwards. Ergonomically and in terms of working conditions, this is ideal because it minimises duty on wrists and shoulders.
- All electrical connections are 'plug and play', meaning that replacement of defect parts happens quickly and easily. A cleverly designed diagnosis system helps you with tracking down malfunctions and guarantees less standstill during maintenance.

OMNIDEL 50/50

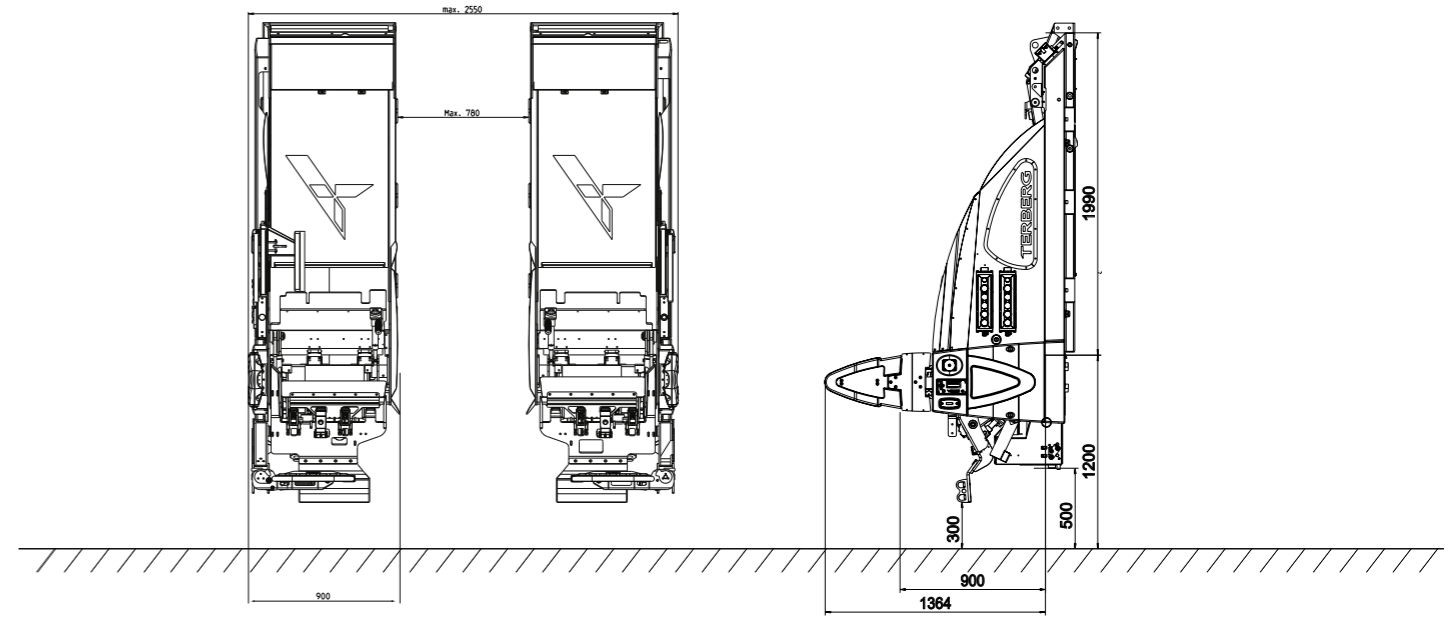

TECHNICAL SPECIFICATIONS



Chair configuration	Single chair	Split chair
Control method	Automatic and Manual	Automatic and Manual
Single Point Greasing	Standard	Standard
Diagnostic display	Standard	Standard
Auto Reverse Raise	Standard	Standard
Anti-Spillage Sonar Sensor	Standard	Standard
Rear Protection Device	Standard	Standard
Terberg Weighing & RFID preparation	Option	Option
EN840.1 containers (80-360 ltr.):**	Standard	Standard
EN840.2 containers (500-1200 ltr.)	Not available	Not available
EN840.3 containers (770-1300 ltr.)	Not available	Not available
Paladin containers with conversion bars	Not available	Not available
Lifting capacity	100 Kgs	100 Kgs
Weight per side	330 Kgs	
Power source	Hydraulic / electric	
Electrical connections	16-pin / 24v	
Waterproof ratings	Proximity switches/sensor to IP86	
Hydraulic connections	quick release couplings (DIN 2353, NW13, NW20)	
Hydraulic requirement	min 20 ltr/min, max 30 ltr/min., 180 bar	
Cycle time	Auto > 2-wheel containers 6.0 secs (+dwell 0.5-1.5) / Manual > 12.0 secs	
Noise level	< 57db (A)	
Safety	CE machinery directive certification, EN 1501.1 & EN 1501.5	