

ELITE 6 - 6x4

Wide Track

Euro 6 SPECIFICATIONS

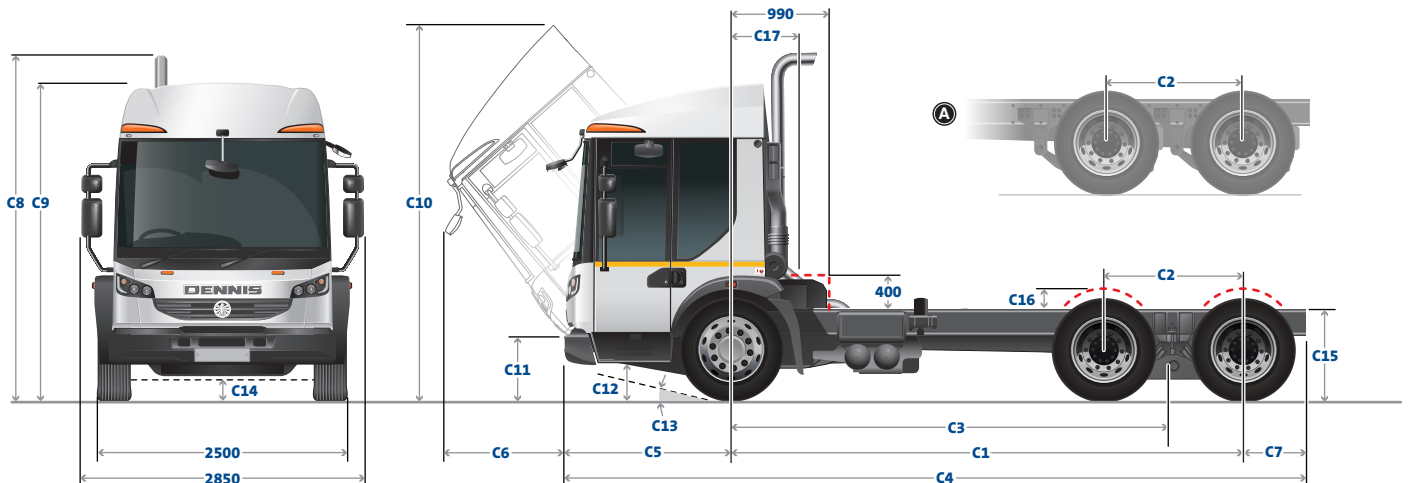

Seating position options

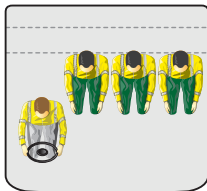

Driver +3

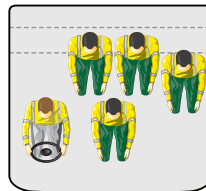

Driver +4

Wheel plan

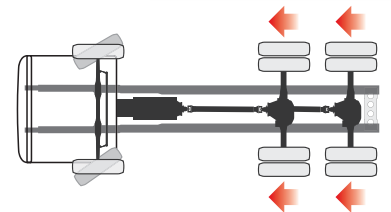

	C1	C2	C3	C4	C5	C6	C7	C8	C9	C10	C11	C12	C13	C14	C15	C16	C17
C1 Overall wheelbase	5200	5300	5400	5600	5800	6000	6200										
C2 Axle 2-3 spread	1385 (1350 [†])																
C3 Theoretical wheelbase	4507.5 (4525 [†])	4607.5 (4625 [†])	4707.5 (4725 [†])	4907.5 (4925 [†])	5107.5 (5125 [†])	5307.5 (5325 [†])	5507.5 (5525 [†])										
C4 Minimum overall length[§]	7515	7615	7715	7915	8115	8315	8515										
Turning circle - overall (metres)	18.8	19.1	19.4	20.0	20.6	21.2	21.8										
Maximum plated vehicle weight	26000																
Front axle maximum weight	8000 (7100 [*])																
Rear axle(s) maximum weight	19000																
Unladen vehicle weight	7760	7780	7800	7840	7880	7920	7960										
Front axle unladen weight	4510	4520	4530	4550	4570	4590	4610										
Rear axle(s) unladen weight	3250	3260	3270	3290	3310	3330	3350										
Tyres - axle 1	315/80R22.5 [*]																
Tyres - axle 2	11R22.5 ^{**}																
Tyres - axle 3	11R22.5 ^{**}																
Tyres - axle 4	-																
C5 Front overhang	1665																
C6 Clearance - cab tilted	1800																
C7 Rear overhang	Minimum 650																
C8 Overall height to exhaust tip - nominal	3500, optional high exhaust 3800 (maximum allowable)																
C9 Cab roof height	3130																
C10 Cab roof height - tilted	3690																
C11 Cab floor height	825 Driver side, 885 Passenger side																
C12 Cab step height	495																
C13 Approach angle	15.5°																
C14 Ground clearance at lowest part of vehicle	250																
C15 Chassis frame height	960																
C16 Minimum road wheel clearance	180																
C17 Minimum body mounting position possible	650																

([§]) Excludes front view mirror which adds approx. 230 mm.

([†]) Optional Primaax air suspension 'A'.

(^{*}) Optional 295/80R22.5 tyres/7100 Front axle maximum weight.

(^{**}) Optional 295/80R22.5 tyres.

NOTE: Unless otherwise stated, all dimensions are nominal, in mm and represent an unladen vehicle fitted with standard tyres; tyre deflection is not included. All specifications are subject to manufacturers tolerances. An allowance of +/- 2% should be made for all weights. All weights are in kgs and include oil and water, and on diesel fuelled vehicles, AdBlue and 50 litres of fuel. Additional equipment may alter dimensions and weights quoted.

DENNIS EAGLE



Cab

- Low walk-through floor with one step entry.
- Cromwell stainless steel construction.
- GRP moulded roof, wings and front grille.
- Manually operated hydraulic cab tilt mechanism.
- Standard seating for driver + 3 crew.
- Crew alternative with driver + 1 or driver + 4 accommodation.

Comfort & Safety

- Adjustable air suspended driver's seat with head and arm rest.
- Adjustable steering column with radio/cluster control stalk, lighting control stalk and optional exhaust brake/retarder stalk.
- Individual crew seats with head rests.
- Integral 3-point inertia-reel seat belts for driver and crew.
- Washable vinyl seat trim.
- Heavy duty washable floor covering.
- Interior lamps with directable reading lamp.
- Tinted glass throughout with deeper side windows for greater visibility.
- Electric windows with dual controls.
- Two half-width sun-blinds.
- Electrically adjustable/heated rear view mirrors.
- Heated wide-angle rear view mirrors.
- Kerb and front view mirrors.
- 2 speed and intermittent windscreen wipers with electric washers.
- Heavy duty heater with 3 speed blower.
- Hi-Flow air conditioning (option).
- Adjustable fascia air vents.

Stowage

- Rear wet area with coat hooks for driver + 3 crew.
- Document stowage net.
- Roof console stowage cupboards.
- Parking brake-actuator wind-off spanner and cab-tilt-pump handle behind driver's seat.

Chassis Frame

- Pressed steel channel section, bolted construction.
- Front under-run protection.
- Frame width: 890 mm.
- Rail section: 260 x 100 x 10 mm.
- 1500 mm rear overhang available (option).

Performance Data

- Maximum speed: 56 mph (speed limited).
- Stall gradeability: 280 bhp - 37%
320 bhp - 39%

Dennis Eagle Ltd. (the company) reserves the right to change the specification, design, material, procedures and dimensions of the vehicles described herein without prior notice at any time in the future, in accordance with the company's constant product improvement policy.

© Dennis Eagle Ltd. 2013

www.dennis-eagle.com
 e: sales@dennis-eagle.co.uk
 t: +44 (0) 1926-458500
 Dennis Eagle Ltd, Heathcote Way, Heathcote Industrial Estate, Warwick CV34 6TE. UK

Engine

- Volvo (Euro 6) D8K 280/320 bhp, 6 cylinder, 7.7 litre in-line diesel.
- Electronic fuel injection.
- SCR treatment with EGR & DPF Filter required for Euro 6 compliance.
- Maximum power: 280 bhp 210 kW
320 bhp 240 kW.
- Maximum torque: 280 = 1050 Nm @ 950 - 1700 rpm
320 = 1200 Nm @ 1050 - 1600 rpm.

Fuel System

- Aluminium fuel tank with lockable cap, anti-siphon and anti-spill as standard. Capacity options of 90, 150 or 280 litre (20, 33 or 61 gallon) subject to space availability / wheelbase.
- Fuel micro-filter, heater & pump filter.
- 32 litre AdBlue Reservoir.
- NOx Control to Euro 6 Standard.

Exhaust

- Side mounted exhaust with Volvo SCR/EGR after treatment and Diesel Particulate Filter and vertical stack pipe.

Gearbox

- Allison MD 3000, 6 speed automatic.
- Electronic push-button control.
- Ratios:

1st	3.487	5th	0.750
2nd	1.864	6th	0.650
3rd	1.400	Reverse	5.027
4th	1.000		

Axles

Steer

- Dana NDS80 forged "I" section.
- Design capacity: 8000 kg.

Drive

- Dana GI50 series.
- Ratio: 7.17:1.
- Combined design capacity: 20000 kg.
- Inter-axle differential lock.

Suspension

Front

- Full air self-levelling suspension with anti-roll bar.
- Telescopic dampers.

Drive

- HN460 rubber suspension as standard.
- Optional Primaax self-levelling air suspension with chassis raise and chassis lower functions.
- Telescopic dampers.

Steering

- Integrally powered recirculating ball - 5 turns lock to lock (approx).

Brakes

- Full air - Twin circuit.
- 4S3C+ EBS with Electronic Stability Program and integral axle weight indication system.
- Traction control (ASR) and Hill Start system. (not available with rear step installations for Eire).
- Disc brakes to all wheels - automatic adjustment and asbestos free pads.
- 4-wheel parking brake.
- Water-cooled compressor: Twin cylinder - 720 cc.
- Audible and visual "low air" warning in cab.

Road Wheels

- Pressed steel spigot mounted 10 stud wheels, 22.5 in. diameter.

Electrical System

- 24 volt, negative earth.
- Battery: Low maintenance, heavy duty with 180 ampere/hour capacity.
- Alternator: 110 amp.
- LED Daytime Running Lights (dim for indicator operation).
- Twin, electrically adjustable headlamps.
- Integral 4 bank LED roof beacons & 2 front mounted grille beacons.
- In-dash 12 V power supply socket.
- Provision for Tachograph & radio/CD player in header panel (2 speakers fitted as standard).
- Provision for load cell weighing systems and monitor/display units in header panel (3 DIN slots).
- On-board diagnostics within display unit with 24 hour digital clock.
- Electronic instruments include - speedometer - tachometer - coolant temperature - fuel level - AdBlue level gauge and service brake air pressure gauge.
- Information screen within instrument cluster displays fuel consumption data and vehicle system fault messages.
- Exhaust Gas Regeneration status indicator with manual control switch on dash.
- Access to fuses and relays in cab behind driver's seat.
- Integrated CANbus/control screen with integral axle load weight indication when supplied with Dennis Eagle Olympus Body Note - Chassis-cabs have dash mounted axle load weight display with +/- 3% accuracy available as an option.

Options

For more details of specifications and options please consult a Dennis Eagle Sales representative.